



**BLACK & DECKER®**

# Thunder Volt™

24 Volt Cordless System



**Instruction Manual**  
*A Breakthrough in Cordless  
Power Tool Technology!*



## Table of Contents

Introduction .....3

Safety Instructions (for all tools) .....6

Drills, Hammerdrill, Screwdriver/Drill .....7

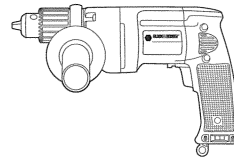

Screwdrivers .....11

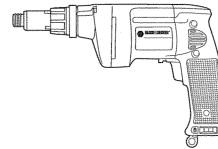

Rotary Hammer .....17

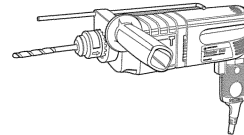

Shear .....21

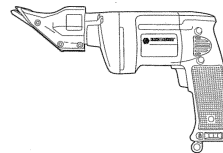

Battery Pack & Battery Charger .....24

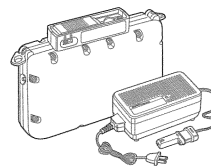

Charger from Vehicle &  
Automotive Charging Adaptor .....27

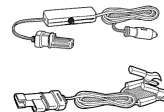

Accessories .....31

Warranty .....32

# INTRODUCTION TO THUNDERVOLT

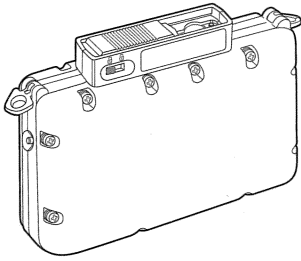

- 98021 12/24 volt battery pack**
- 12 & 24 volt outputs
  - portable & wearable
  - long run time

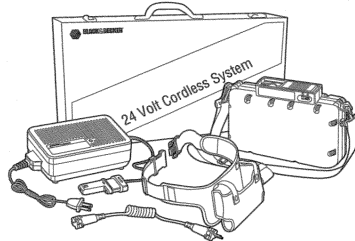

- 1820 Thundervolt Kit**
- Starter kit for the system
  - Tools purchased separately
  - Kit includes: Battery Pack, Charger, 6ft. (1.8M) coiled cable, Battery Belt & Pouch, Battery Strap and Steel Kit Box

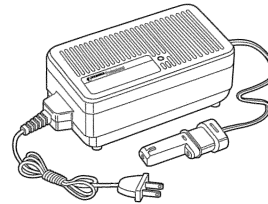

- 98009 24 volt battery charger**
- charges in one hour or less
  - LED light indicates charge condition

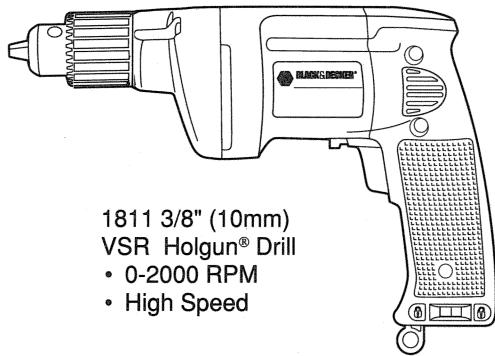

- 1811 3/8" (10mm) VSR Holgun® Drill**
- 0-2000 RPM
  - High Speed

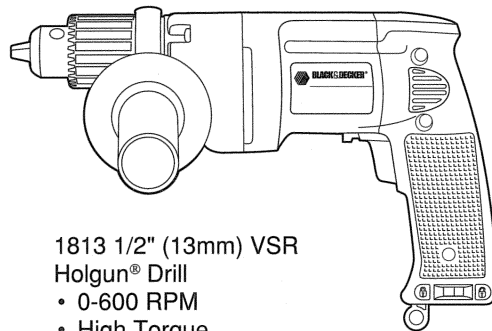

- 1813 1/2" (13mm) VSR Holgun® Drill**
- 0-600 RPM
  - High Torque

## Thanks for Selecting Thundervolt

**Convenience and versatility of cordless power tools with the power and performance of corded power tools.**

Thundervolt is a whole new concept for cordless power tools that has been engineered and designed to be the best, most advanced cordless power tool system in the world. Thundervolt is not just one tool, but a whole range of industrial quality power tools all working from the same 12/24 volt battery pack. Users of the Thundervolt system will be able to dramatically improve their productivity on the job by using this flexible multi tool system. State of the art technology has been incorporated into the battery pack; the heart of the 24 volt system. It can be worn, carried, or

placed adjacement to the work area. It has both 12 and 24 volt outputs, excellent run time and it can be fully charged in one hour or less by an electronic one hour battery charger.

The Thundervolt battery pack will power a wide variety of high performance industrial power tools making Thundervolt one of the most flexible power tool systems available. The battery pack is connected to the tool by either a 6 foot (1.8m) coiled cable or a 13 foot (4.0m) straight cable. The range of tools includes Holgun® Drills, a Scrudrill® Screwdriver/Drill, a Ham-mergun® Hammerdrill, Scrugun® Screwdrivers, an SDS Plus Rotary Hammer, and a Swivel Head Shear.



# INTRODUCTION TO THUNDERVOLT

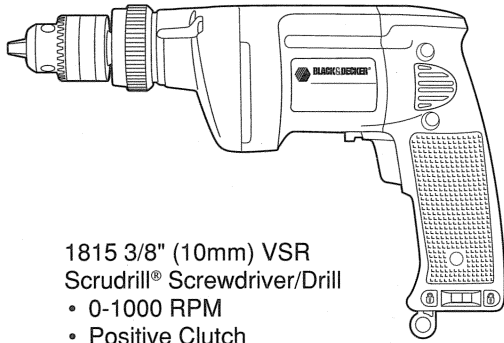

1815 3/8" (10mm) VSR  
Scrudrill® Screwdriver/Drill

- 0-1000 RPM
- Positive Clutch

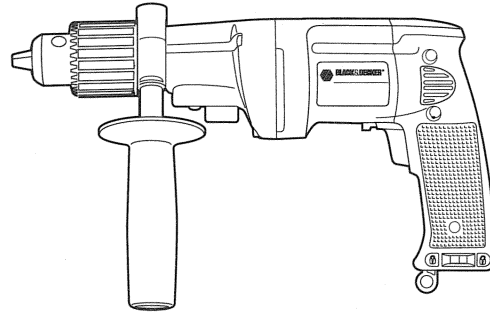

1817 1/2" (13mm) 2 Speed  
VSR Holgun® Drill

- 0-800/0-1800 RPM
- High Torque or high speed

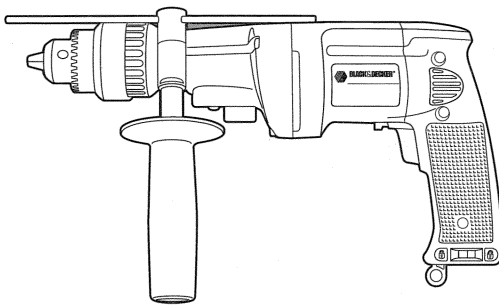

1819 1/2" (13mm) VSR Hammergun®  
Hammerdrill

- 0-800/0-1800 RPM
- Maximum Versatility

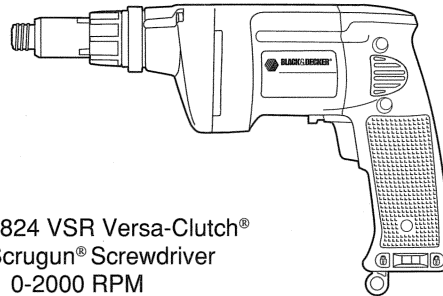

1824 VSR Versa-Clutch®  
Scrugun® Screwdriver

- 0-2000 RPM
- Patented Versa-Clutch® design

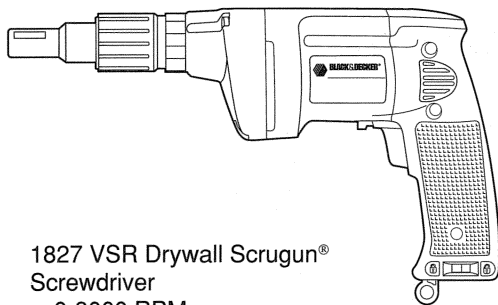

1827 VSR Drywall Scrugun®  
Screwdriver

- 0-3000 RPM
- Set & forget nosepiece

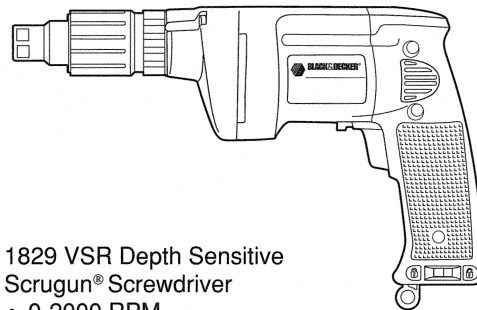

1829 VSR Depth Sensitive  
Scrugun® Screwdriver

- 0-2000 RPM
- Set & forget nosepiece

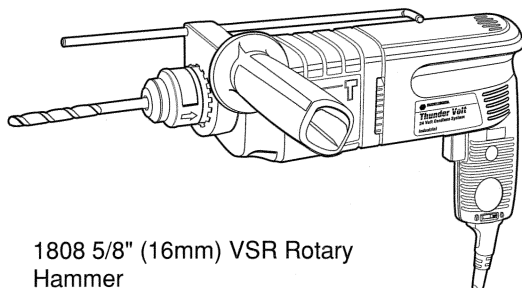

1808 5/8" (16mm) VSR Rotary  
Hammer

- 0-615 RPM
- SDS Bit Retention

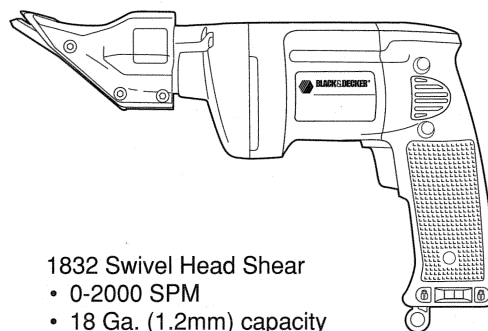

1832 Swivel Head Shear

- 0-2000 SPM
- 18 Ga. (1.2mm) capacity

## Nothing but the Best

Thundervolt tools include nothing but the best when it comes to components. The list includes an electronic switch module which improves performance and actually maintains the desired speed under load. The motor is a fan cooled permanent magnet motor which improves the tools' efficiency and allows both increased torque and increased run time. Other features include metal gear housings for durability, ball and roller bearing construction, cut steel gears, large long life brushes and high impact abuse resistant housings. While the features do vary by tool, all the tools have been engineered for industrial use and continuous use applications. Thundervolt - Nothing but the Best!

## Accessories

The accessories listed in this manual are available at extra cost from your local dealer or Black & Decker Service Center.

Recommended accessories for your tool are shown in this manual (CAUTION: The use of any other accessories or attachments may be hazardous.)

98009	24 Volt Charger
98021	12/24 Volt Battery Pack
98024	Battery Pack Belt & Pouch
98027	Battery Pack Shoulder Strap
98028	Holster
98031	6 Foot (1.8M) Coiled Cable
98032	13 Foot (4.0M) Cable
98034	Charger from vehicle
98035	Automotive charging adaptor

## Increased Productivity

The Thundervolt system provides a series of important end user benefits. When they all come together, they mean that the Thundervolt user will be able to improve their productivity on the job. Big jobs get done faster and with less effort. To the industrial or construction power tool user, time is money. Thundervolt is ideal for maintenance crews, mechanical contractors, service trades, the military, the government, roofers, metal building erectors and others. Thundervolt will ultimately save the end user both time and money. Check out these system benefits:

- Power tools with the convenience and versatility of cordless tools, yet the power and performance of corded power tools.
- A flexible, multi-tool system all working from the same battery pack.
- Advanced battery and tool technology provides dramatically improved run time.
- An electronic charger provides fast charging in one hour or less.
- Thundervolt provides the user with fast set-up, especially when compared to generators and extension cords.
- Improved Safety. Safety concerns about electric shock with generators and long, cumbersome and frayed extension cords are eliminated. With Thundervolt, the user can even use power tools in wet and damp environments without the fear of shock hazards.
- On the job site, Thundervolt can actually replace generators or long extension cords.

## Thundervolt vs. the Generator

Generator Disadvantages....

- Expensive
  - Heavy/Clumsy
  - Noisy
  - Constant servicing
  - Fuel/Oil
  - Time Consuming
- ....Are Eliminated!

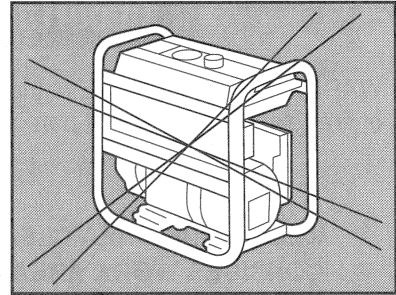

## Thundervolt vs. Long Extension Cords

Extension Cord Disadvantages....

- Piles of Cords/Tangling
  - Time Consuming
  - Power Loss on long leads
  - Wear and tear on the tool
  - Won't work in all applications
- ....Are Eliminated!

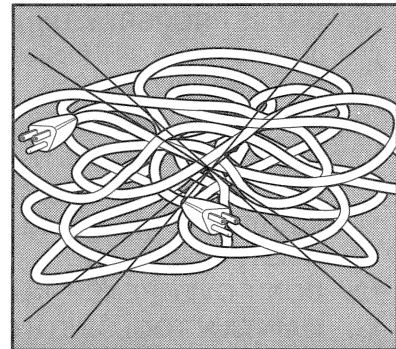

What's it all mean? Increased Productivity! Black and Decker's Industrial Power Tool Division is so confident that the user will improve productivity, that we're going to guarantee it!

See your Thundervolt distributor for details.

# SAFETY INSTRUCTIONS

## Important Safety Instructions (For All Tools)

**WARNING:** When using Electric Tools, basic safety precautions should always be followed to reduce risk of fire, electric shock, and personal injury, including the following:

### READ ALL INSTRUCTIONS

1. **KEEP WORK AREA CLEAN.** Cluttered areas and benches invite injuries.
2. **CONSIDER WORK AREA ENVIRONMENT.** Don't expose battery charger to rain. Don't use battery charger in damp or wet locations. Keep work area well lit.
3. **DO NOT OPERATE** portable electric tools near flammable liquids or in gaseous or explosive atmospheres. Motors in these tools normally spark, and the sparks might ignite fumes.
4. **KEEP CHILDREN AWAY.** All visitors should be kept away from work area. Do not let visitors contact tool, charger, or extension cord.
5. **STORE IDLE TOOLS.** When not in use, tools should be stored in dry, and high or locked-up place - out of reach of children.
6. **DON'T FORCE TOOL.** It will do the job better and safer at the rate for which it was intended.
7. **USE RIGHT TOOL.** Don't force small tool or attachment to do the job of a heavy-duty tool. Don't use tool for purpose not intended, for example, don't use circular saw for cutting tree limbs or logs.
8. **DRESS PROPERLY.** Do not wear loose clothing or jewelry. They can be caught in moving parts. rubber gloves and non-skid footwear are recommended when working outdoors. Wear protective hair covering to contain long hair.
9. **USE SAFETY GLASSES.** Also use face or dustmask if operation is dusty.
10. **DON'T ABUSE CORD.** Never carry tool by cord or yank it to disconnect from receptacle. Keep cord from heat, oil, and sharp edges.
11. **SECURE WORK.** Use clamps or a vise to hold work. It's safer than using your hand and it frees both hands to operate tool.
12. **DON'T OVERREACH.** Keep proper footing and balance at all times.
13. **MAINTAIN TOOLS WITH CARE.** Keep accessories sharp and clean for better and safer performance. Follow instructions for lubricating and changing accessories. Inspect tool cords periodically and if damaged have repaired by authorized service facility. Inspect extension cords periodically and replace if damaged. Keep handles dry, clean, and free from oil and grease.
14. **DISCONNECT TOOLS.** When not in use, before servicing, and when changing accessories, such as blades, bits, cutters.
15. **REMOVE ADJUSTING KEYS AND WRENCHES.** Form habit of checking to see that keys and adjusting wrenches are removed from tool before turning it on.
16. **AVOID UNINTENTIONAL STARTING.** Don't carry plugged-in tool with finger on switch. Be sure switch is off when plugging in.
17. **OUTDOOR USE EXTENSION CORDS.** Use only extension cords intended for use outdoors and so marked. (See page 26, item 9.)
18. **STAY ALERT.** Watch what you are doing. Use common sense. Do not operate tool when you are tired.
19. **CHECK DAMAGED PARTS.** Before further use of the tool, any part that is damaged should be carefully checked to determine that it will operate properly and perform its intended function. Check for alignment of moving parts, binding of moving parts, breakage of parts, mounting, and any other conditions that may affect its operation. Any part that is defective should be properly repaired or replaced by an authorized service center unless otherwise indicated elsewhere in this instruction manual. Have defective switches replaced by authorized service center. Do not use tool if switch does not turn it on and off.

## SAVE THESE INSTRUCTIONS

**Holgun® DRILLS, Hammergun® HAMMERDRILL,  
Scrudrill® SCREWDRIVER/DRILL**



**BLACK&DECKER®**

**ThunderVolt™**  
24 Volt Cordless System

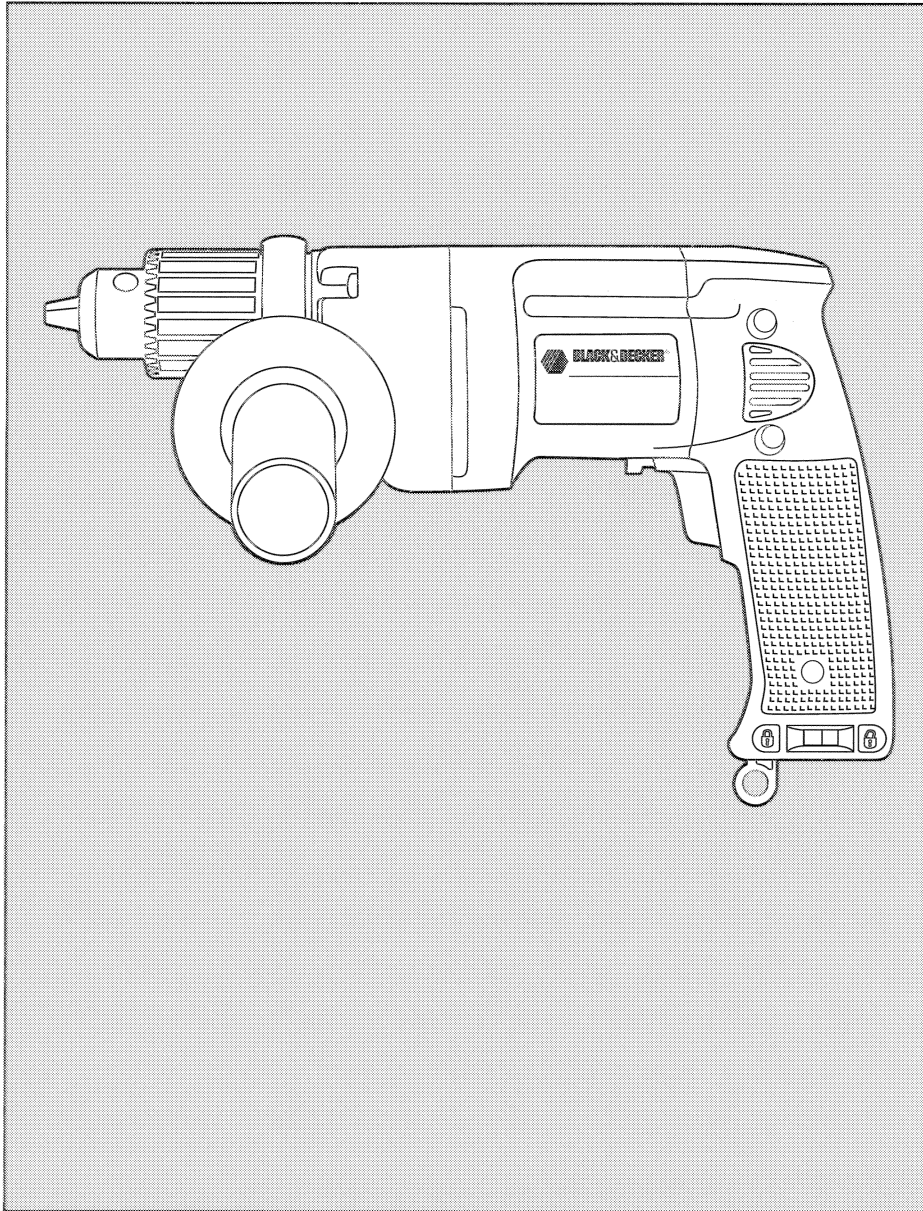

**1811 3/8" (10mm) VSR Holgun® Drill**

**1813 1/2" (13mm) VSR Holgun® Drill**

**1815 3/8" (10mm) VSR Scrudrill® Screwdriver/Drill**

**1817 1/2" (13mm) 2 Speed VSR Holgun® Drill**

**1819 1/2" (13mm) 2 Speed VSR Hammergun® Hammerdrill**

# Holgun® DRILLS, Hammergun® HAMMERDRILL, Scrudrill® SCREWDRIVER/DRILL

## Detachable Cord Sets

The two available detachable cord sets for your tools are designed to be interchangeable depending on the proposed usage. (See page 31.)

To attach either of the cords to any of the tools in this manual, follow the steps listed below.

1. Rotate the cord locking tab such that the tab is adjacent to the "unlocked" symbol, as shown in Figure 1.

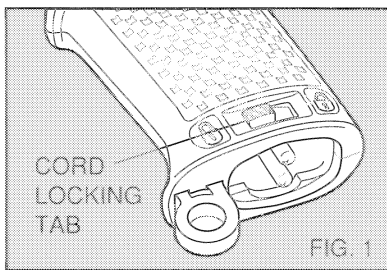

2. Insert the cord, as shown in the figure and rotate the locking tab until it is adjacent to the "locked" symbol. **NOTE:** The cord will only fit one way.

Attach the other end of the cord to the battery pack in the same way making sure that you insert the cord into the 24 volt receptacle in the battery pack (see Figure 2 on page 25). **NOTE:** All of the tools discussed in this manual are designed to operate on 24 volts only. For a more detailed description of how to use the battery pack, refer to page 24.

## Switches

To start tool, depress trigger switch; to stop tool, release trigger switch, as shown in Figure 3.

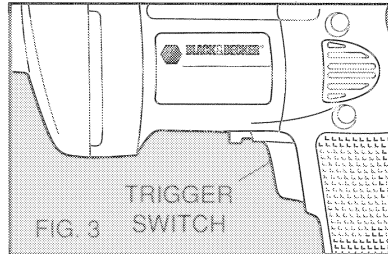

**The Variable Speed Trigger Switch** permits speed control — the farther the trigger is depressed, the higher the speed of the Drill. **NOTE:** Use lower speeds for starting holes without a center punch, drilling in metal or plastics, driving screws, drilling ceramics, or mixing paint. Higher speeds are better for drilling wood and composition boards, and for using abrasive and polishing accessories.

**The reversing lever** can be used to shift the tool into reverse for backing out screws and withdrawing drill bits from tight holes. To switch the tool from forward to reverse, turn off the tool and move the reversing lever shown in Figure 4 to the left, as viewed in the figure.

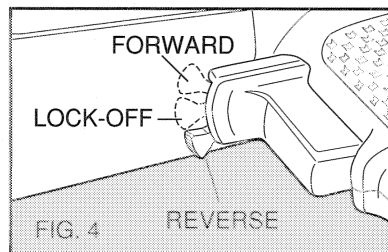

The reversing lever performs two functions; it reverses the tool and it locks the tool off. The center position is "lock-off" and should be used whenever the tool is put away, holstered or left unattended (refer to Figure 4).

After any reversing operations, return the lever to the forward position.

The 1811 and 1813 Holgun® Drills, as well as the 1815 Scrudrill® Screwdriver Drills are standard variable speed reversing tools. The 1811 has a speed range of 0-2000 RPM, the 1813 from 0-600 and the 1815 runs from 0-1,000 RPM.

The 1817 1/2" (13mm) Holgun® drill and the 1819 1/2" (13mm) Hammergun® Hammerdrill are 2 speed, variable speed reversing tools. The low speed range on each is from 0 to 800 RPM and the high speed range is from 0 to 1,800 RPM. To select the low speed setting on either of these two tools, turn the tool off and rotate the Range Selector Dial, shown in Figure 5, to align with the number "I". To select the high speed setting on either of these two tools, turn the tool off and rotate the Range Selector Dial, shown in Figure 5, to align with the number "II". Any position of the dial other than I or II will result in seriously damaged gears.

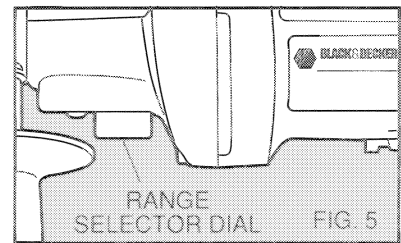

After selecting the desired speed range, the 1817 and the 1819 2 speed tools will operate the same as the variable speed reversing tools.

## Chuck

Open chuck jaws by turning collar with fingers and insert shank of bit about 3/4" (19mm) into chuck. Tighten chuck collar by hand. Place chuck key in each of the three holes, and tighten in clockwise direction. It's important to tighten chuck with all three holes to help prevent bit slippage. To release bit, turn chuck key counterclockwise in just one hole, then loosen the chuck by hand.

## 1811, 1813, 1817 Drills

### Drilling In Metal

Use a cutting lubricant when drilling metals. The exceptions are cast iron and brass which should be drilled dry. The cutting lubricants that work best are sulphurized cutting oil or lard oil; bacon-grease will also serve the purpose.



# Holgun® DRILLS, Hammergun® HAMMERDRILL, Scrudrill® SCREWDRIVER/DRILL

## Drilling In Wood

Holes in wood can be made with the same twist drills used for metal. These bits may overheat unless pulled out frequently to clear chips from the flutes. For larger holes, use Power Drill Wood Bits. Work that is apt to splinter should be backed up with a block of wood.

## Drilling In Masonry

Use carbide tipped masonry bits at low speeds. Keep even force on the drill but not so much that you crack the brittle materials. A smooth, even flow of dust indicates the proper drilling rate.

## 1815 3/8" (10mm) Scrudrill® Screwdriver/Drill

The Scrudrill® Screwdriver/Drill is a combination drill and screwdriver that you'll find to be a great time saver.

To use this tool as a drill, rotate the selector collar shown in figure 6 so that the pictured drill bit is toward the chuck end of the tool. Use the drill as you would any drill.

To select the screwdriving mode, rotate the selector collar so that the pictured screw is toward the chuck end of the tool as shown in the figure. In this mode the motor will run when the trigger is squeezed but the chuck will not turn until you push in on the tool and engage the clutch. This enables you to locate the screwdriver bit in the screw without turning the tool off.

Try a few test screws in scrap material until you develop a "feel" for the Scrudrill® Screwdriver/Drill.

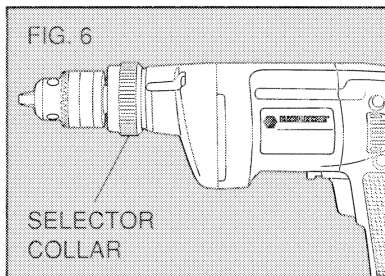

## 1819 1/2" (13mm) Hammergun® Hammerdrill

The Hammerdrill is a drill especially made for drilling holes in

masonry where a slight impacting action is required. The Hammerdrill, as its name implies, can also be used as a standard drill.

## Collar Shift Operation

**TO HAMMER** - Rotate the collar shown in Figure 7, while pulling out toward end of chuck, to align the Hammer symbol at top of tool. This is the position to be used with Percussion type Carbide-tipped Bits for drilling in tile, masonry, brick, porcelain, etc.

**TO DRILL** - Rotate the collar shown in Figure 7 to align the drill bit symbol at top of tool. This position is for drilling metal with drill bits, in wood with wood augers or when using hole saws for cutting wood, metal or composition materials.

**TURN COLLAR ONLY WHEN CHUCK IS NOT ROTATING.**

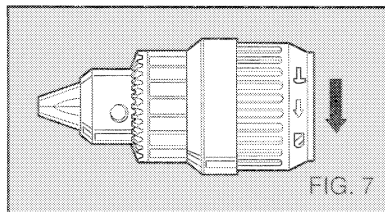

## Operation

### DRILLING

1. Always unplug the tool when attaching or changing bits or accessories.
2. Use sharp drill bits only. For WOOD, use twist drill bits, spade bits, power auger bits, or hole saws. For METAL, use high speed steel twist drill bits or hole saws. For MASONRY, such as brick, cement, cinder block, etc., use carbide-tipped bits.
3. Be sure the material to be drilled is anchored or clamped firmly. If drilling thin material, use a wood "back-up" block to prevent damage to the material.
4. Always apply pressure in a straight line with the bit. Use enough pressure to keep bit biting, but do not push hard enough to stall the motor or deflect the bit.
5. Hold tool firmly to control the twisting action of the tool.
6. **IF TOOL STALLS**, it is usually because it is being overloaded or improperly used. **RELEASE**

**TRIGGER IMMEDIATELY**, remove drill bit from work, and determine cause of stalling. **DO NOT CLICK TRIGGER OFF AND ON IN AN ATTEMPT TO START A STALLED TOOL — THIS CAN DAMAGE THE TOOL.**

7. To minimize stalling or breaking through the material, reduce pressure on tool and ease the bit through the last fractional part of the hole.
8. Keep the motor running when pulling the bit back out of a drilled hole. This will help prevent jamming.
9. With Variable Speed Tools there is no need to center punch the point to be drilled. Use a slow speed to start the hole and accelerate by squeezing the trigger harder when the hole is deep enough to drill without the bit skipping out.

## Side Handle

**CAUTION:** Always use side handle when provided and hold tool with both hands. (Side handles provided with 1813, 1817 & 1819.)

The side handle clamps to the front of the gear case as shown in Figure 8 and can be rotated 360 degrees to permit right or left hand use. Loosen the handle (counterclockwise) to loosen the clamp and rotate handle to desired position. Tighten handle.

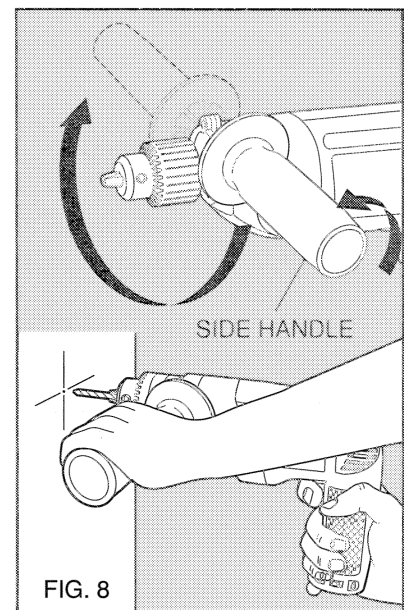

# Holgun® DRILLS, Hammergun® HAMMERDRILL, Scrudrill® SCREWDRIVER/DRILL

## Chuck Key Holder

1. Push double-hole end of Holder through slot in other end of Holder (Figure 9).
2. Slip loop over electric plug and draw loop tight around cord (Figure 10).
3. Push ends of Chuck Key Handle through two holes in end of Holder (Figure 11).

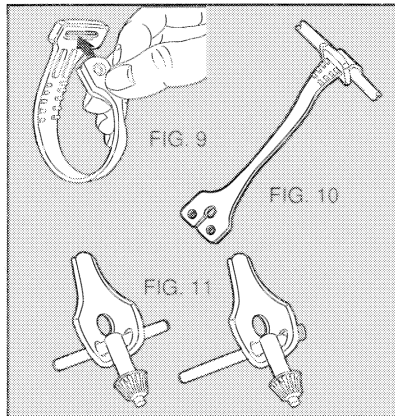

## Chuck Removal

(Figures 12 and 13)

1. Place chuck key in chuck as shown in Figure 12. Using a wooden mallet or similar object, strike key sharply in a **CLOCKWISE** direction. This will loosen screw inside chuck.

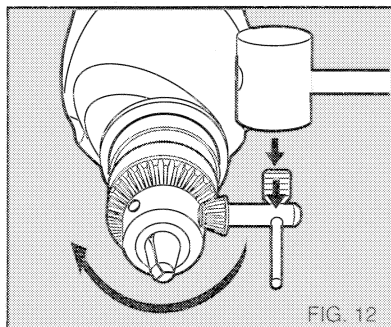

2. Open chuck jaws fully, insert screwdriver (or 3/16" (5mm) hex wrench if required) into front of chuck between jaws to engage screw head. Remove screw by turning clockwise (left-hand- thread).

3. Place key in chuck as shown in Figure 13. Using a wooden mallet or similar object, strike key sharply in a **COUNTER-CLOCKWISE** direction. This will loosen chuck so that it can be unscrewed by hand.

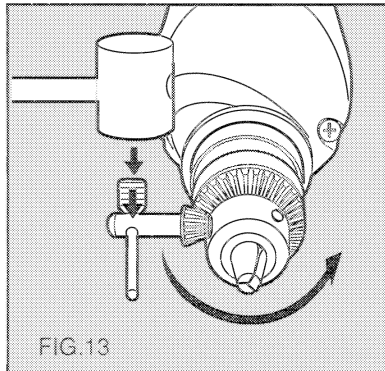

## Accessories

The accessories listed in this manual are available at extra cost from your local dealer or Black & Decker Service Center.

Recommended accessories for your tool are shown in this manual (**CAUTION:** The use of any other accessories or attachments may be hazardous.) For safety in use, the following accessories should be used only in sizes up to maximums shown in the table below.

## Maximum Recommended Capacities

TOOL CAPACITY	1/2" (13mm)	3/8" (10mm)
BITS, METAL DRILLING	1/2" (13mm)	3/8" (10mm)
SOFT WOOD, FLAT BORING	1-1/2" (38mm)	1-1/4" (32mm)
BITS, MASONRY DRILLING	9/16" (14mm)	9/16" (14mm)
HOLE SAWS	3" (76mm)	1-1/2" (38mm)

ACCESSORY MUST BE RATED FOR USE AT SPEED EQUAL TO OR HIGHER THAN NAMEPLATE R.P.M. OF TOOL WITH WHICH IT IS BEING USED.

WIRE WHEEL BRUSHES	4" (102mm) Diameter Maximum
WIRE CUP BRUSHES	3" (76mm) Diameter Maximum
BUFFING WHEELS	3" (76mm) Diameter Maximum
RUBBER BACKING PADS	4-5/8" (117mm) Diameter Maximum

## Lubrication

All ball bearings used are factory lubricated to last the life of the bearings. All roller bearings used receive their lubrication from the grease in the gear case. Clean and re-lubricate gear case yearly or whenever servicing requires the gear case to be removed. Use type and quantity of grease shown on Parts Bulletin packed with your tool.

Gear case is removed by removing the three screws from the front of the tool.

## Cleaning

With the motor running, blow dirt and dust out of all air vents with dry air at least once a week. Wear safety glasses when performing this. Exterior plastic parts may be cleaned with a damp cloth and mild detergent. Although these parts are highly solvent resistant, **NEVER** use solvents.

**SCRUGUN® SCREWDRIVERS**



**ThunderVolt™**  
24 Volt Cordless System

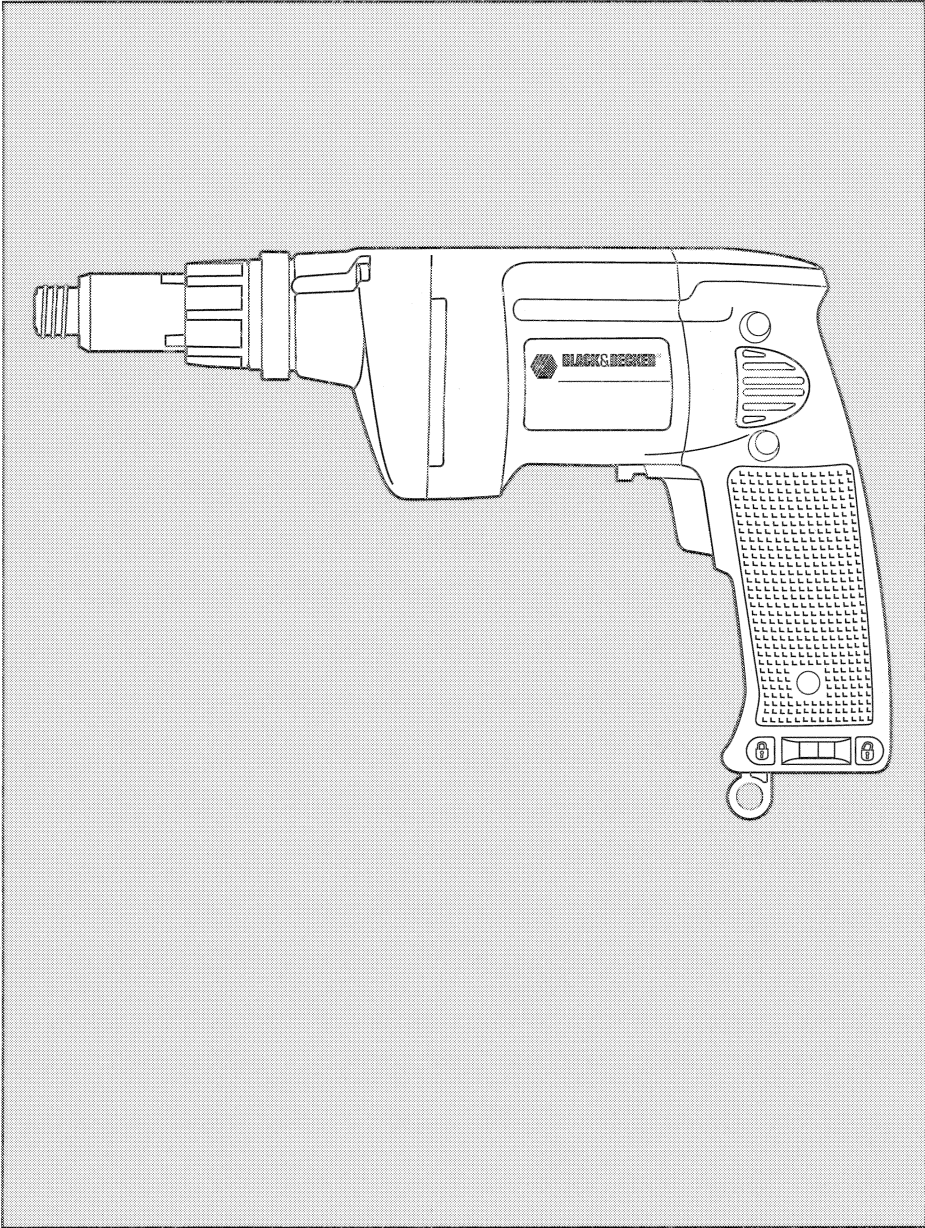

- 1824 VSR Versa-Clutch® Scrugun® Screwdriver**
- 1827 VSR Drywall Scrugun® Screwdriver**
- 1829 Depth Sensitive Scrugun® Screwdriver**

# SCRUGUN® SCREWDRIVERS

## Detachable Cord Sets

The two available detachable cord sets for your tools are designed to be interchangeable depending on the proposed usage. (See page 31.)

To attach either of the cords to any of the tools in this manual, follow the steps listed below.

1. Rotate the cord locking tab such that the tab is adjacent to the "unlocked" symbol, as shown in Figure 1.

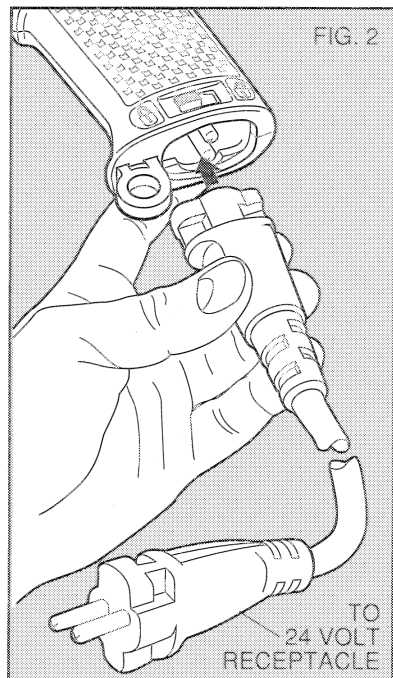
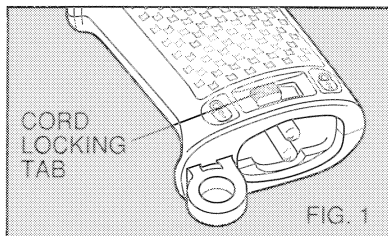

2. Insert the cord, as shown in the figure and rotate the locking tab until it is adjacent to the "locked" symbol.

NOTE: The cord will only fit one way.

Attach the other end of the cord to the battery pack in the same way making sure that you insert the cord into the 24 volt receptacle in the battery pack (see Figure 2 on page 25). NOTE: All of the tools discussed in this manual are designed to operate on 24 volts only. For a more

detailed description of how to use the battery pack, refer to page 24.

## Switches

To start tool, depress trigger switch; to stop tool, release trigger switch, as shown in Figure 3.

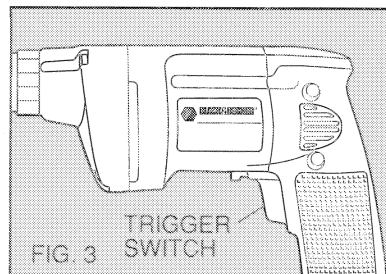

**The Variable Speed Trigger Switch** permits speed control — the farther the trigger is depressed, the higher the speed of the Screwdriver.

### Scrugun® Screwdrivers

**1824 Versa Clutch® - 0-2,000 rpm**

**1827 Drywall - 0-3,000 rpm**

**1829 Depth Sensitive - 0-2,000 rpm**

**The reversing lever** can be used to shift the tool into reverse for backing out fasteners. To switch the tool from forward to reverse, turn off the tool and move the reversing lever shown in Figure 4 to the left, as viewed in the figure.

The reversing lever performs two functions; it reverses the tool and it locks the tool off. The center position is "lock-off" and should be used whenever the tool is put away, holstered or left unattended (refer to Figure 4).

After any reversing operations, return the lever to the forward position.

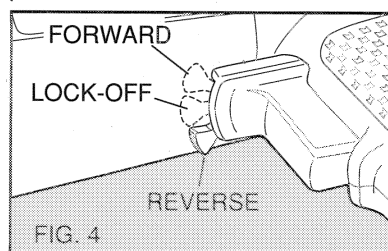

## Bit Installation

**1827 DRYWALL & 1829 DEPTH SENSITIVE SCRUGUNS**

Your scrugun has a 1/4" (6mm) Hex Drive Ball Lock Chuck designed to hold the screwdriver

bit. To install a bit, insert the hex end into the chuck and tap it lightly, as shown in Figure 5, until it snaps into place.

Pliers will usually be required to remove the screwdriver bit from this type of chuck.

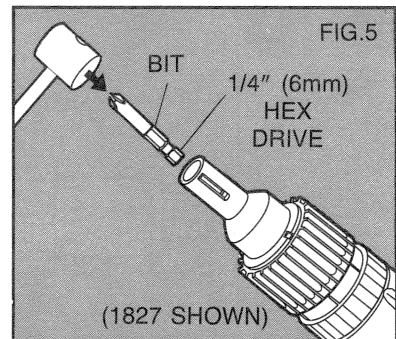

## 1824 VERSA-CLUTCH SCREWDRIVER ONLY

Your Versa-Clutch screwdriver utilizes a 1/4" (6mm) Hex Drive Quick Change Chuck for fast bit changing to enhance versatility. To install a bit or nutsetter, pull the ball retainer forward, as shown in Figure 6, as you insert the hex end of the bit or nutsetter into the chuck. Release the ball retainer and it will snap back, locking the bit into place. When you wish to remove the bit, simply pull out on the ball retainer and withdraw the bit.

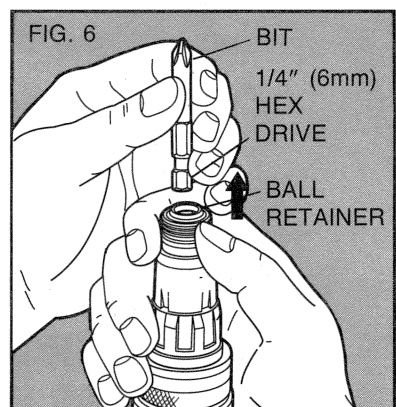

## Depth Adjustment on 1827 Drywall & 1829 Depth Sensitive Scruguns

1. Rotate the adjusting collar clockwise (when viewed from

the bit end) to provide deeper seating of screws. Rotate the collar counterclockwise to seat screws less deep.

2. Test drive a fastener into scrap material to determine if correct depth is being achieved.

These screwdrivers have very fine depth settings. Each "click" equals .007" (.177mm). One complete revolution of the adjusting collar equals .083" (2.108mm) change in depth setting.

## Adjustment of 1824 Versa-Clutch® Scrugun® Screwdriver

1. Pull out on the adjusting collar and rotate it clockwise (when viewed from the bit end) to increase clutch engagement for higher torque. Rotate the collar counterclockwise to decrease clutch engagement and reduce torque.
2. Test drive a fastener into scrap material to determine if fastener seating is as desired. Adjust the clutch accordingly.

**NOTE:** It is normal to require some readjustment of the clutch after extensive use to offset clutch face wear.

## Dead Spindle Action

All Black & Decker Scrugun® Screwdrivers provide a "DEAD" front spindle to permit engagement of fastener with bit or other driving accessory. Clutches are held apart by light spring pressure permitting the driving clutch to rotate and not contact the driven clutch. When sufficient forward pressure is applied, the clutches will engage and drive the bit and fastener.

## 1827 Drywall & 1829 Depth Sensitive Scrugun® Screwdrivers

Recommended for 14 & 16 ga. studs and multiple board layers using long drill point drywall screws.

Your screwdriver is designed to operate with all commercially available drywall screws.

1. Install Drywall Bit in Bit Holder.
2. Adjust Depth Locator.
3. Check for correct rotation, start screwdriver and place drywall screw on bit.
4. Contact drywall applying forward pressure to drive screw until depth locator contacts work surface. Screwdriver will ratchet automatically disengaging bit from screw.

## 1824 Versa-Clutch® Scrugun® Screwdriver

1. Install proper fastener driving accessory and set screwdriver for correct rotation.
2. Adjust clutch setting.
3. Place fastener in accessory, contact workpiece and apply pressure to seat fastener keeping clutches engaged.
4. Upon fastener seating the clutches will ratchet. Disengage screwdriver from fastener.

**NOTE:** With Versa-Clutch® the operator has the ability to "override" clutch ratchet if a fastener hits a wood knot, variable hardness in steel workpieces or incorrect pilot holes. Increased operator pressure will usually cause the clutches to "pick-up" and continue to seat the fastener. Further, a quick twist of the collar will change the clutch setting to overcome most driving difficulties and will provide for immediate change in torque output giving the operator option to drive a range of fastener sizes.

## Maintenance: Cleaning

With the motor running, blow dirt and dust out of all air vents with dry air at least once a week. Wear safety glasses when performing this. Exterior plastic parts may be cleaned with a damp cloth and mild detergent. Although these parts are highly solvent resistant, **NEVER** use solvents.

## Drywall & Depth Sensitive Scrugun® Screwdrivers

Depth locator and adjustment collar should be removed, and dust blown out of clutch housing area at least once a week.

## Changing Clutches

1. Remove clutch housing by unscrewing (left hand thread).
2. Clamp tool or clutch housing in a resilient clamp.
3. Remove round clutch retaining rings with a very small screwdriver or sharp pointed tool, as shown in Figure 7.

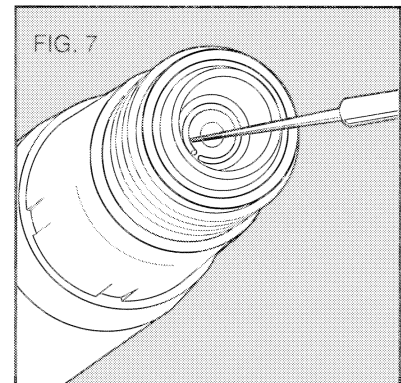

# SCRUGUN® SCREWDRIVERS

- Install new clutches and new retaining rings.  
**NOTE:** If the output spindle slides toward inside of gear case, remove dead spindle spring and insert needle nosed pliers into end of spindle and lift up to expose retaining ring groove. Re-assemble dead spindle spring allowing no more than 1/4" (6mm) projecting from end of spindle.
- Relubricate clutches. (See lubrication)

## Lubrication

All ball bearings and roller bearings are factory lubricated for the life of the bearings. Roller bearings receive additional lubrication from the grease in the gear case. Gearing and gear case should be re-lubricated every six months or when gear case is removed for servicing as follows: (more often if the tool is used constantly on production jobs)

- Remove gear case.
- Clean out old grease and thoroughly clean all parts.
- Relubricate gear box and gearing with the quantity of B&D Heavy Duty grease called for on Parts Bulletin.
- Reassemble tool.

Clutches should be lubricated at same time the gearing is relubricated in accordance with the following procedure:

- Remove clutch housing by unscrewing (left hand thread).
- On Drywall unit slip clutch assembly from clutch housing.
- Lightly brush or coat areas marked A, B in Figure 8 with B&D Clutch Grease. Coat clutch face inside nose of gear case.
- On Versa-Clutch units the clutch assembly will not slip out of the clutch housing. It is necessary only to coat the clutch faces on these units.
- Reassemble clutch housing.

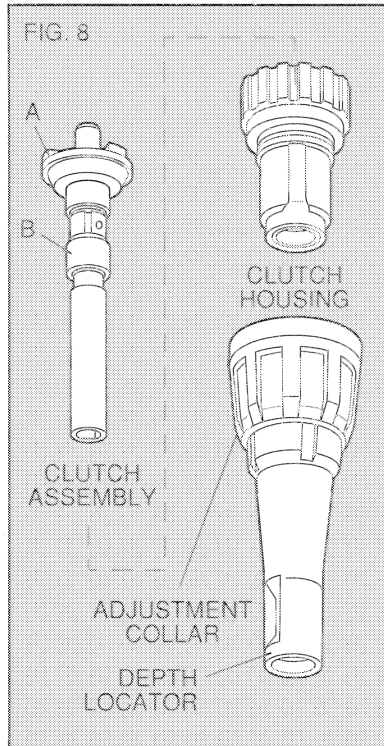

## Accessories







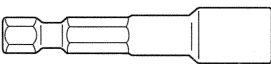

The accessories listed in this manual are available at extra cost from your local dealer or Black & Decker Service Center.

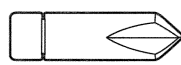
Recommended accessories for your tool are shown in this manual (**CAUTION:** The use of any other accessories or attachments may be hazardous.)

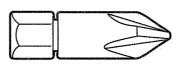

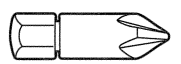
### Hex Shank Bit Tip Holders for Non-Drywall Screwdrivers

	TYPE	LENGTH
 1/4" (6mm) HEX SHANK FOR 1/4" (6mm) TIP	NON-MAGNETIC	2-1/8" (54mm)
	MAGNETIC	2-1/8" (54mm)



### Hex Shank Insert Bits for Bit Tip Holders

	SCREW TYPE	POINT SIZE
 	PHILLIPS	1 2 3
		2 drywall
 	FREARSON REED & PRINCE	6 & larger 5 & larger
 	PHILLIPS POSIDRIVE	
 	SOCKET HEAD CAP SCREWS	1/8" (3mm) 5/32" (4mm) 3/16" (5mm)

**Hex Shank Power Bits**

	SCREW TYPE	POINT SIZE	LENGTH
	 PHILLIPS	1	1-15/16" (49mm)
		2	1-15/16" (49mm)
		2	1-15/16" (49mm)
		2	3-1/2" (90mm)
		3	1-15/16" (49mm)
2	3-1/2" (90mm)		
 PHILLIPS POSIDRIVE	2	1-15/16" (49mm)	
	3	1-15/16" (49mm)	

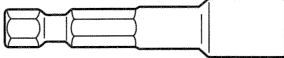
**1/4" (6mm) Hex Drive Nutsetters - for driving hex head fasteners**

 	TYPE	SOCKET SIZE	LENGTH
	Non-Magnetic	1/4" (6mm)	2-9/16" (65mm)
		5/16" (8mm)	2-9/16" (65mm)
		3/8" (10mm)	2-9/16" (65mm)
	Magnetic	1/4" (6mm)	1-5/8" (41mm)
		1/4" (6mm)	2-9/16" (65mm)
5/16" (8mm)		2-9/16" (65mm)	
3/8" (10mm)	2-9/16" (65mm)		

**Hex Drive Shank Extensions**

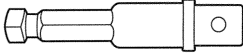
 *For use with 1/4" (6mm) square drive sockets - 1/4" (6mm) hex	SHANK SIZE	SQ. DR.	LENGTH
	1/4" (6mm)	1/4" (6mm)	2" (51mm)
1/4" (6mm)	1/4" (6mm)	6" (152mm)	







**Sockets for the above:**

	TYPE	SOCKET SIZE	DIAM.	LENGTH
	Non-Magnetic	1/4" (6mm)	1/2" (13mm)	7/8" (22mm)
		5/16" (8mm)	1/2" (13mm)	7/8" (22mm)
		3/8" (10mm)	9/16" (14mm)	15/16" (24mm)
	Magnetic	1/4" (6mm)	7/16" (11mm)	7/8" (22mm)
		5/16" (8mm)	1/2" (13mm)	7/8" (22mm)
3/8" (10mm)		9/16" (14mm)	7/8" (22mm)	

\*For std. "soft" screws.

†For sheet metal, Tek, self-tapping screws.

# SCRUGUN® SCREWDRIVERS

SCREW TYPE AND NUMBER SIZE					
					
FLAT OR OVAL	ROUND	FILLISTER	BINDING	PAN	TRUSS

## 1/4" (6mm) Hex Bits For Slotted Head Screws

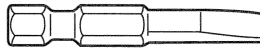

3,4	3,4	4, 5	3	4	2
5	5	6	4	5	3, 4
6	6	8	5	6	-
8	8	10	6, 8	8	5, 6
10	10	12	10	10	8
12, 14, 1/4	12, 14, 1/4	1/4	12, 1/4	12, 1/4	10
12	14, 1/4	1/4	12	12	10

## 1/4" (6mm) Hex Bits With Rotating Finder For Use With Any 1/4" (6mm) Hex Drive Power Tool

						BIT LENGTH
4, 5	4, 5	4, 5, 6	4, 5	4, 5	-	3-1/2" (89mm)
8	8	8, 10	6	8	5, 6	3-1/2" (89mm)
8	8	8, 10	6	8	5, 6	6" (152mm)
10	10	12	8, 10	10	8, 10	3-1/2" (89mm)
12	12	1/4	-	12	-	3-1/2" (89mm)

## Misc. Screwdriver Accessories

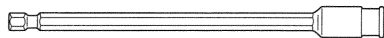

6" (152mm) Hex Bit Extension  
For use with 1/4" (6mm) Hex  
Shanks and/or other extensions.

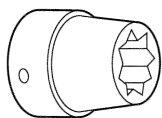

1/4" (6mm) Square Drive Magnetic  
Socket For driving 8 Pointed Nylon  
and Steel Headed Screws.

Magnetic Bit Tip Holders for Drywall  
Scruguns

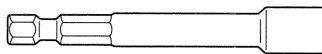

1/4" (6mm) Hex Shank for 1/4"  
(6mm) Hex Tip (2 31/32" (75mm)  
long) for use with Type 6, and Type  
5 Drywall Scruguns

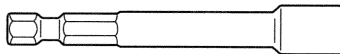

1/4" (6mm) Hex Shank for 1/4"  
(6mm) Hex Tip (3" (76mm) long) for  
use only with Type 4 and Type 3  
and older models

Nutsetters

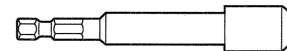

3-3/16" (81mm) length  
For 5/16" (8mm) Hex Head Screws



# ROTARY HAMMER



**ThunderVolt™**  
24 Volt Cordless System

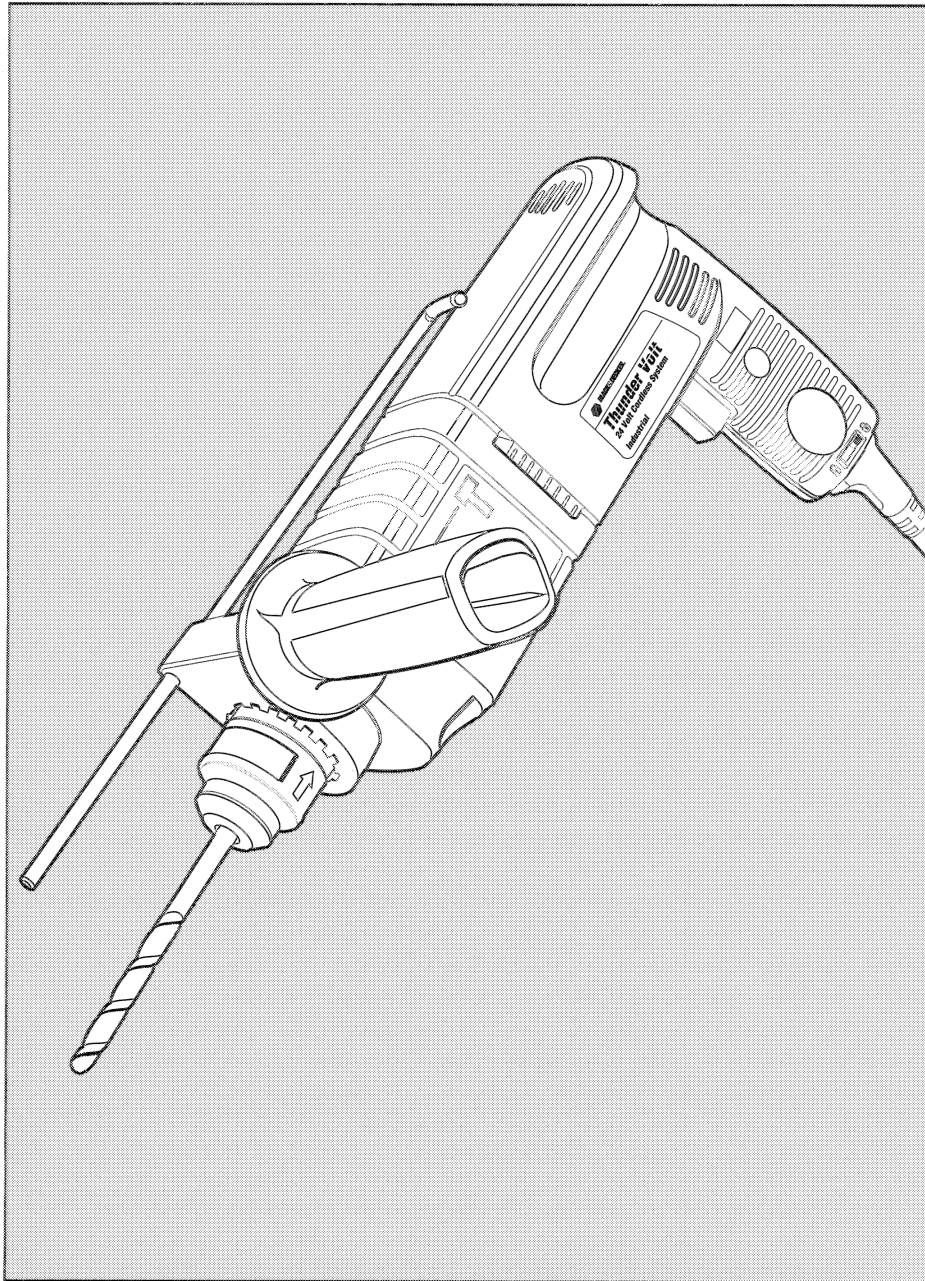

**1808 5/8" (16mm) Rotary Hammer**

# ROTARY HAMMER

## Detachable Cord Sets

The two available detachable cord sets for your tools are designed to be interchangeable depending on the proposed usage. (See page 31.)

To attach either of the cords to your hammer, follow the steps listed below.

1. Rotate the cord locking tab such that the tab is adjacent to the "unlocked" symbol, as shown in Figure 1.

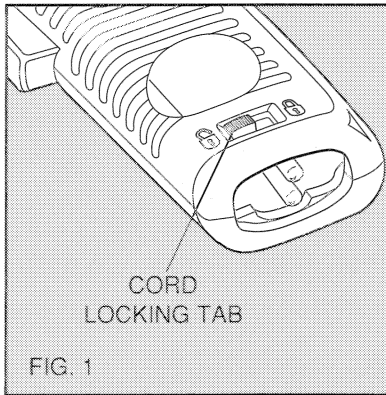

2. Insert the cord, as shown in the figure and rotate the locking tab until it is adjacent to the "locked" symbol, as shown in the figure.

**NOTE:** The cord will only fit one way.

Attach the other end of the cord to the battery pack in the same way making sure that you insert the cord into the 24 volt receptacle in the battery pack (see Figure 2 on page 25). **NOTE:** Your hammer is designed to operate on 24 volts only. For a more detailed description of how to use the battery pack, refer to page 24.

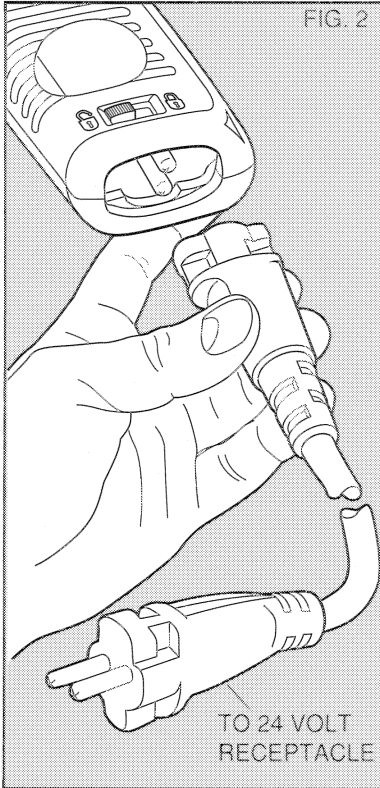

## Switches

To start tool, depress trigger switch; to stop tool, release trigger switch, as shown in Figure 3.

The Variable Speed Trigger Switch permits speed control — the farther the trigger is depressed, the higher the speed of the hammer.

The reversing lever can be used to shift the tool into reverse for backing out jammed drill bits. To switch the tool from forward to reverse, turn off the tool and move the reversing lever shown in Figure 3 to the left, as viewed in the figure.

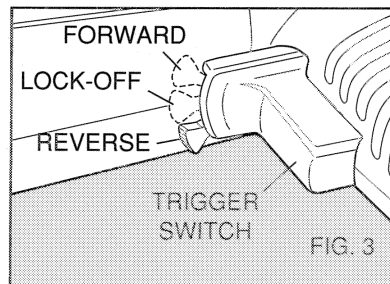

The reversing lever performs two functions; it reverses the tool and it locks the tool off. The center position is "lock-off" and should be used whenever the tool is put away or left unattended (refer to Figure 3).

After any reversing operations, return the lever to the forward position.

## Selector Lever

The selector lever, located as shown in Figure 4, is used for selecting the hammer mode or the drilling mode. With the tool turned "OFF" move the lever to the vertical position, as shown in Figure 4, for hammering. Move it to the horizontal position for drilling operations. Always wait for the tool to stop coasting before moving the selector lever.

Use the hammering mode for drilling holes in masonry. Use the drilling mode when drilling holes in wood, composition board, metals and plastics.

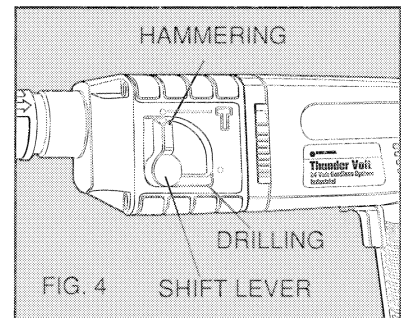

## Side Handle

**CAUTION:** Always use side handle and hold tool with both hands.

The side handle clamps to the front of the gear case as shown in Figure 5 and can be rotated 360 degrees to permit right or left handed use. Loosen the handle (counterclockwise) to loosen the clamp, remove depth rod and rotate handle to desired position. Reinsert depth rod and retighten handle.

The Depth Rod can be adjusted to limit the drilling depth. Loosen the side handle and position as desired.

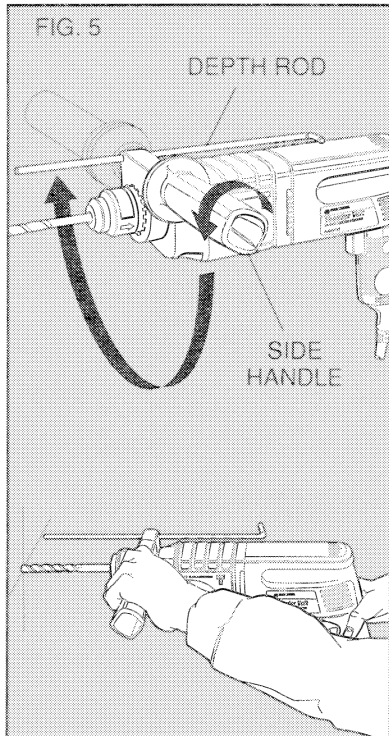

## Bit Insertion

**(TURN OFF AND UNPLUG HAMMER)**

The bit holder on your hammer is designed to hold SDS Plus hammer bits like the one shown in Figure 6. **(IT WILL NOT HOLD ROUND SHANK DRILL BITS.)** Insert a bit into the holder and twist it clockwise as you push it in. You will feel and hear a click as the bit locks into the bit holder.

In order to remove the bit, push the collar on the bit holder back, as shown in Figure 6, as you pull the bit out.

**NOTE:** Insertion and removal of the hammer bit will be somewhat tight because of the close fit of the dust shield around the bit shank.

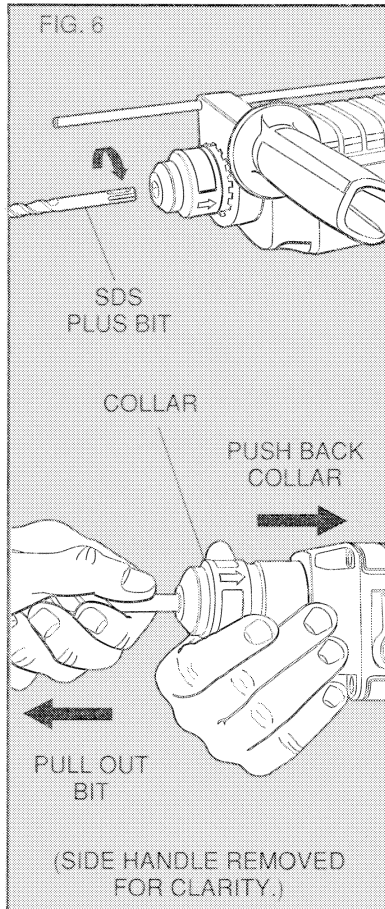

## Accessory Drill Chuck and Adaptor Shank

**(TURN OFF AND UNPLUG HAMMER)**

To make the use of standard round shank drill bits possible, an accessory drill chuck is supplied with your tool. The accessory includes an SDS Plus adaptor shank. Insert the end of the shank into the tool holder as you would any hammer bit (See Figure 7). The tool can then be used as any conventional drill.

**NOTE:** Do not attempt to install an SDS Plus hammer bit into the drill chuck.

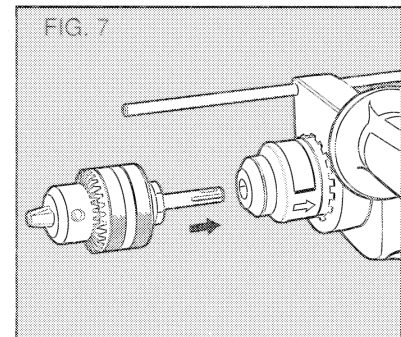

Open chuck jaws by turning collar with fingers and insert shank of bit about 3/4" (19mm) into chuck. Tighten chuck collar by hand. Place chuck key in each of the three holes, and tighten in clockwise direction. It's important to tighten chuck with all three holes. To release bit, turn chuck key counterclockwise in just one hole, then loosen the chuck by hand.

## Chuck Key Holder

1. Push double-hole end of Holder through slot in other end of Holder (Figure 8).
2. Slip loop over electric plug and draw loop tight around cord (Figure 9).
3. Push ends of Chuck Key Handle through two holes in end of Holder (Figure 10).

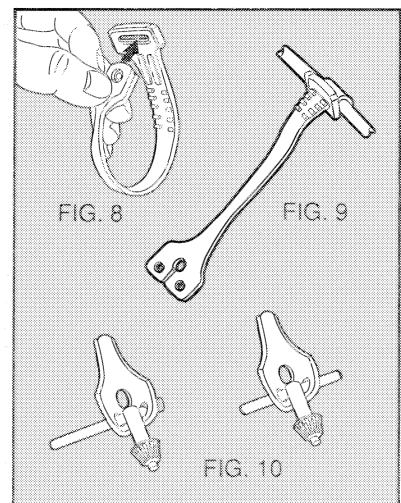

# ROTARY HAMMER

## Maximum Recommended Capacities

TOOL CAPACITY	1/2" (13mm)
R.P.M.	0-615
BITS, METAL DRILLING	1/2" (13mm)
SOFT WOOD, FLAT BORING	1-1/2" (38mm)
BITS, MASONRY DRILLING	5/8" (16mm)
HOLE SAWS	3" (76mm)

ACCESSORY MUST BE RATED FOR USE AT SPEED EQUAL TO OR HIGHER THAN NAMEPLATE R.P.M. OF TOOL WITH WHICH IT IS BEING USED.

WIRE WHEEL BRUSHES	4" (102mm) Diameter Maximum
WIRE CUP BRUSHES	3" (76mm) Diameter Maximum
BUFFING WHEELS	3" (76mm) Diameter Maximum
RUBBER BACKING PADS	4-5/8" (117mm) Diameter Maximum

## Accessories

The accessories listed in this manual are available at extra cost from your local dealer or Black & Decker Service Center.

Recommended accessories for your tool are shown in this manual

(**CAUTION:** The use of any other accessories or attachments may be hazardous.)

## Lubrication

All ball bearings used are factory lubricated to last the life of the bearings. All roller bearings used receive their lubrication from the grease in the gear case. Clean and re-lubricate gear case yearly or whenever servicing requires the gear case to be removed. Use type and quantity of grease shown on Parts Bulletin packed with your tool.

Gear case is removed by removing the three screws from the front of the tool.

## Cleaning

With the motor running, blow dirt and dust out of all air vents with dry air at least once a week. Wear safety glasses when performing this. Exterior plastic parts may be cleaned with a damp cloth and mild detergent. Although these parts are highly solvent resistant, **NEVER** use solvents.



**ThunderVolt™**  
24 Volt Cordless System

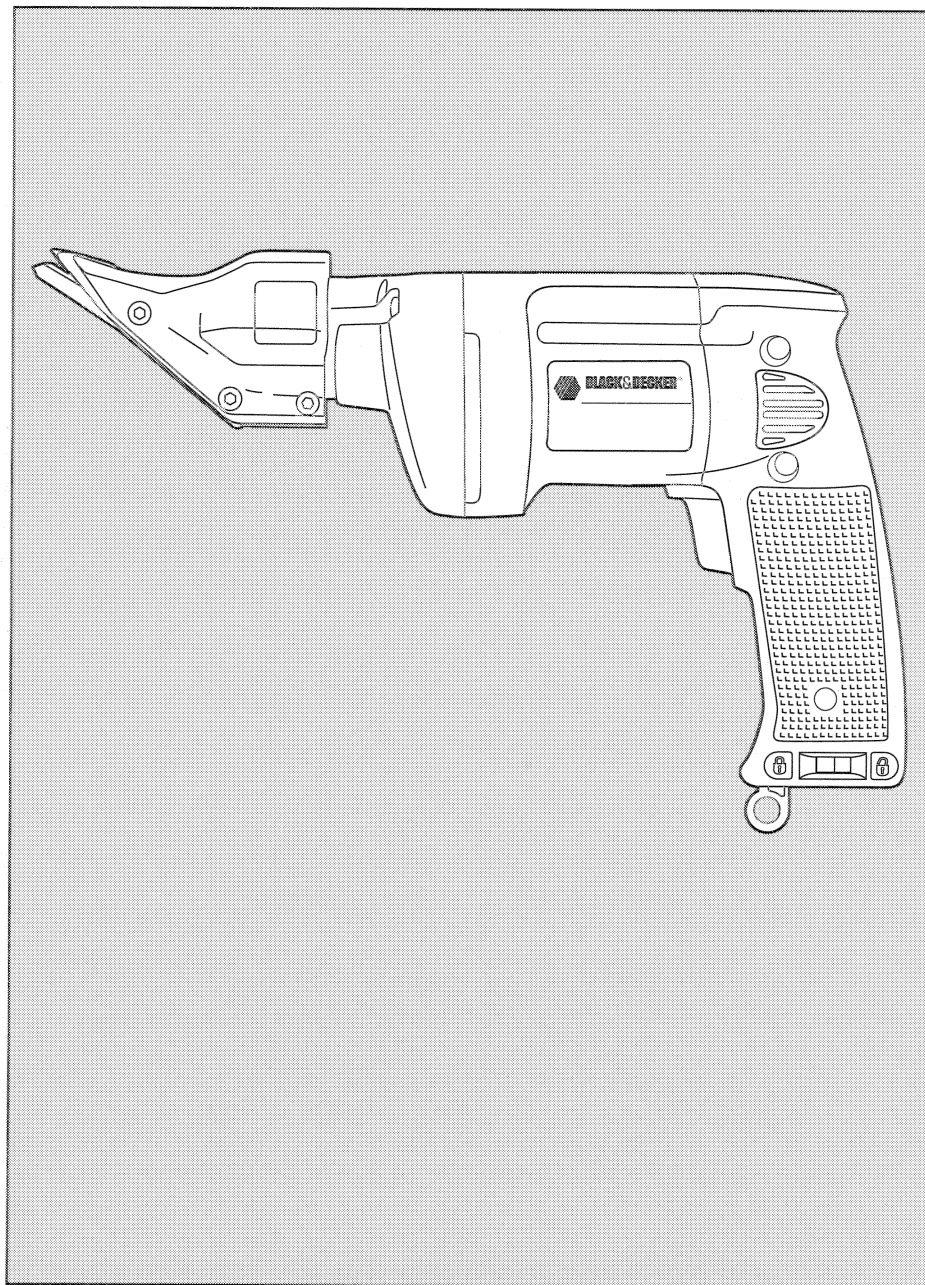

**1832 18 Ga. (1.2mm) Swivel Head Shear**

# SHEAR

## Detachable Cord Sets

The two available detachable cord sets for your tools are designed to be interchangeable depending on the proposed usage. (See page 31.)

To attach either of the cords to your shear, follow the steps listed below.

1. Rotate the cord locking tab such that the tab is adjacent to the "unlocked" symbol, as shown in Figure 1.

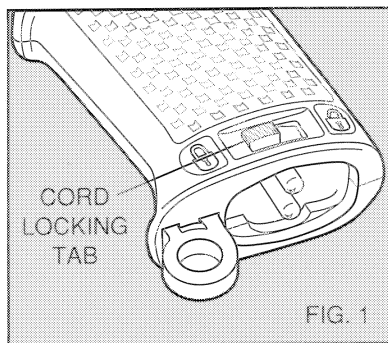

2. Insert the cord, as shown in the figure and rotate the locking tab until it is adjacent to the "locked" symbol, as shown in the figure.

**NOTE:** The cord will only fit one way.

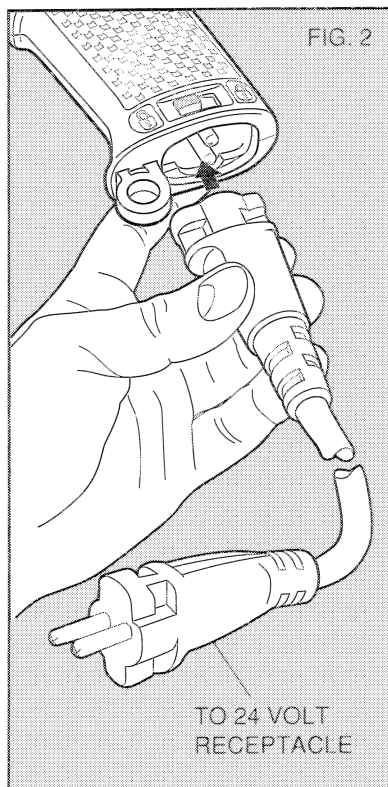

Attach the other end of the cord to the battery pack in the same way making sure that you insert the cord into the 24 volt receptacle in the battery pack (see Figure 2 on page 25). **NOTE:** Your shear is designed to operate on 24 volts only. For a more detailed description of how to use the battery pack, refer to page 24.

## Switches

To start the Shear, depress the trigger switch. To stop the Shear, release the trigger switch.

The Variable Speed Trigger Switch permits speed control - the farther the trigger is depressed, the higher the speed of the Shear. The speed range of your Shear is 0-2000 S.P.M. (strokes per minute).

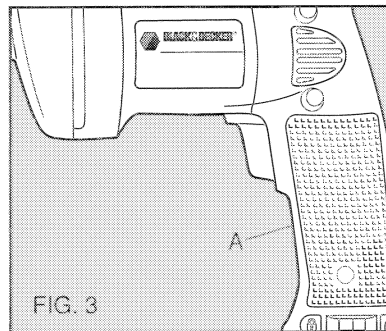

## Operation

Your new 1832 SWIVEL HEAD SHEAR will smoothly cut up to 18 ga. (1.2mm) steel. Its powerful motor is capable of continuous production service and the variable speed switch provides precise cutting control.

For accurate work, always clamp or anchor the material to be cut. Line up one edge of the tool's middle blade with the cutting line and advance blades into the material without forced effort or unnecessary pressure. A little practice will enable you to determine what forward pressure gives you the smoothest cutting.

It is important to keep the lower

surfaces of the side blades flat on the material being cut (Figure 4). When cutting curves, do not tilt the tool; keep the side blades flat and level. For best cutting efficiency, keep blades sharp.

Wear gloves when handling sheet metal. The edges are sharp and can cause injury.

**CAUTION:** Do not use the Shear with any kind of accessory or attachment. Such usage might be hazardous.

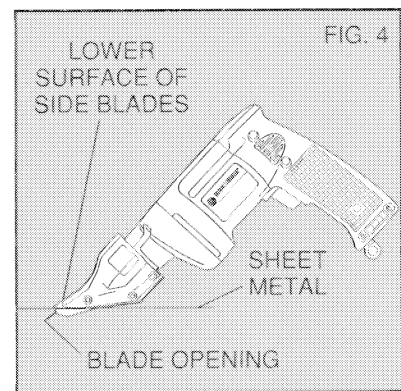

## Adjustment (See Figures 5, 6 & 7)

To adjust the curl of the waste material, the left side knife (G) has elongated holes. Adjustment may be necessary after changing the blades or material being cut. Loosen cap screws (A) and tap side knife (G) either forward or backward so that curl of waste does not hit shear housing (B) or work material while cutting.

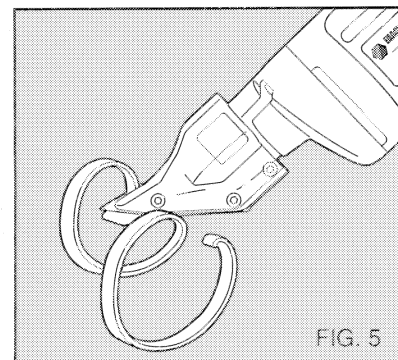

**Disassembly  
(See Fig. 6 and 7)**

To remove shear head from motor loosen three cap screws (A). Remove shear head from motor by pulling head firmly forward. Slight twisting action may be required if head does not slide off easily.

To remove cutter blades from shear head remove three cap screws (A) completely from shear housing (B). Be careful not to lose rear spacer bushing when removing middle cap screw. Remove center blade from shear housing by tapping blade gently rearward. Be careful not to lose spacer bushing from hole in center blade. Side knife and side spacer (C) will now drop out of the shear housing.

To remove eccentric bearing assembly (F) from shaft use an appropriate wrench to loosen eccentric nut by turning counter-clockwise.

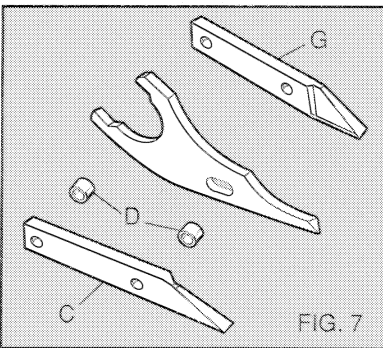
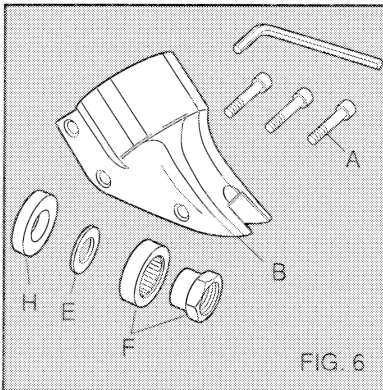

**Assembly  
(See Fig. 6 and 7)**

To install eccentric bearing assembly (F) onto shaft make sure that spacer (H) is on shaft and the large thin washer (E) is inserted over shaft. Screw eccentric bearing assembly onto shaft and tighten with appropriate wrench. Lubricate bearing with a good grade of bearing grease.

To install cutter blades into shear housing (B) place the side knife and side spacer into position in the shear housing (B). Insert center cap screw (A) through side knife and side spacer with rear spacer bushing (D) between them and start cap screw into thread just enough to hold blades in place. **DO NOT TIGHTEN.** Insert spacer bushing (D) into hole in center blade and lubricate with a good grade of bearing grease. Install center blade into shear housing by tapping blade gently forward using a drift to line up hole in center blade with forward holes in housing. Insert and tighten forward cap screw (A) making sure spacer bushing (D) in center blade stays in position. Apply good grade of bearing grease to clevis or yoke in center blade where it rides on the eccentric bearing assembly. Insert rear cap screw (A) into shear housing but do not completely tighten.

To install shear head assembly onto drive motor make sure all cap screws (A) are loosened about three or four complete turns. Place shear head onto unit and tighten cap screws snugly to lock head assembly in place. It may be necessary to gently tap the shear head into place if it does not readily slip onto the nose of the power unit.

**Lubrication**

All ball bearings used are factory lubricated to last the life of the tool. All sleeve & roller bearings used receive their lubrication from the grease in the gear case. Clean and re-lubricate gear case yearly or whenever servicing requires the gear case to be removed. Use type and quantity of grease shown on Parts Bulletin packed with your tool.

Gear case is removed by removing the three screws from the front of the tool.

**Cleaning**

With the motor running, blow dirt and dust out of all air vents with dry air at least once a week. Wear safety glasses when performing this. Exterior plastic parts may be cleaned with a damp cloth and mild detergent. Although these parts are highly solvent resistant, **NEVER** use solvents.

# BATTERY PACK & BATTERY CHARGER



**ThunderVolt™**  
24 Volt Cordless System

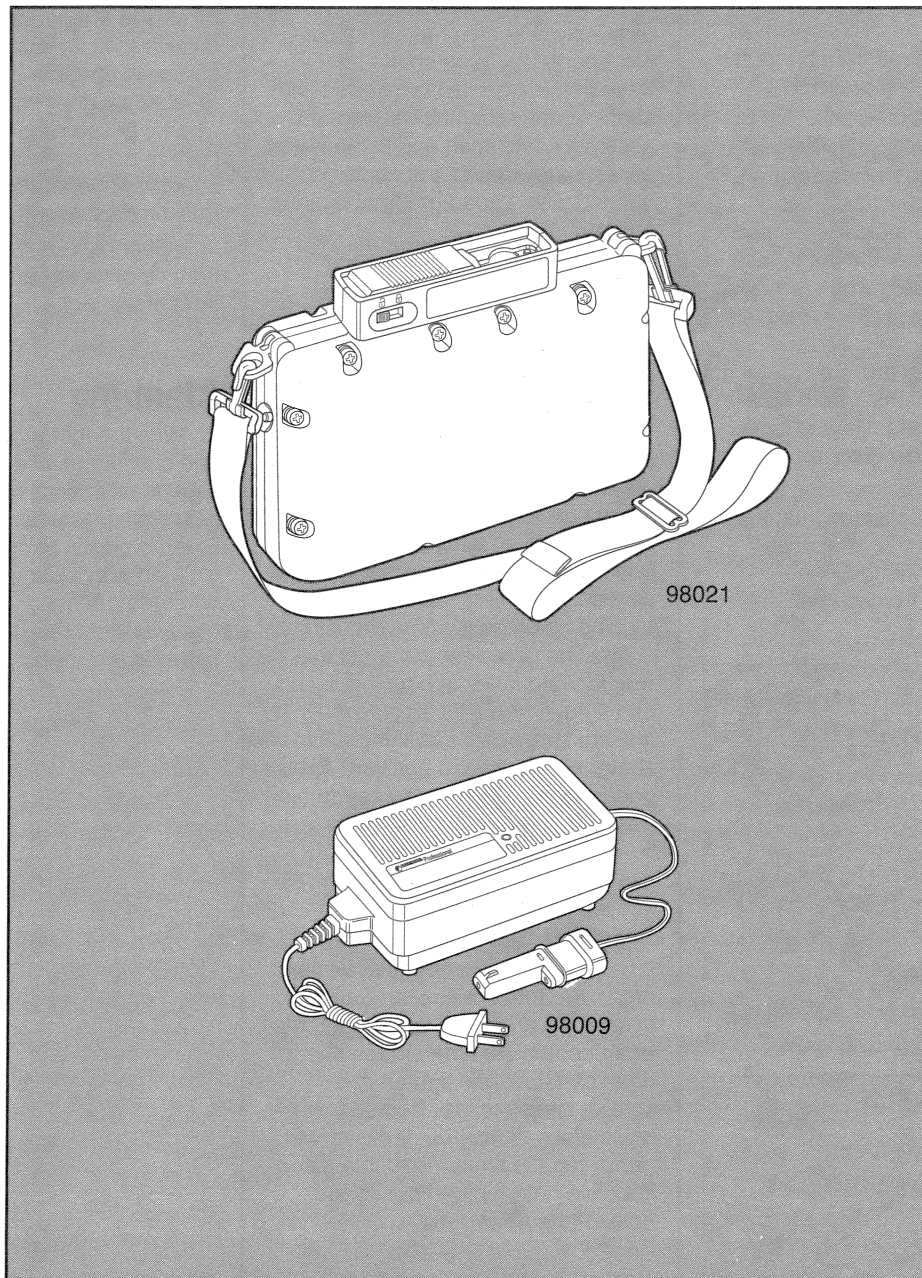

**98021 Battery Pack &  
98009 Battery Charger**



## Thundervolt™ 12 & 24 Volt System Charging Instructions

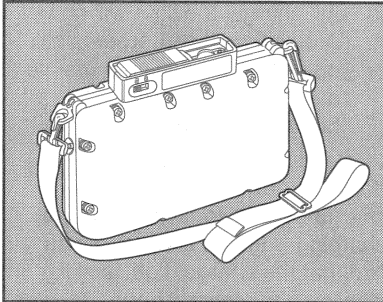

98021 Battery Pack  
Battery Pack shown with No. 98027  
accessory strap.  
(Available at extra cost.)

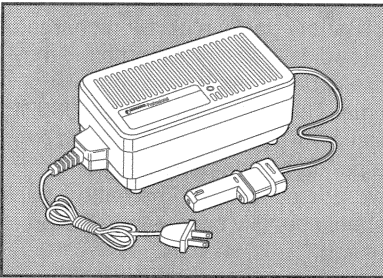

98009 Battery Charger  
High Performance Lead Acid  
Battery Charger

### 98021 Battery Pack

#### Battery Pack Safety Instructions WARNING

1. **STORE AND CHARGE IN A DRY LOCATION** — out of children's reach.
2. **DRESS PROPERLY.** Do not wear any loose clothing or jewelry.
3. **USE ONLY WITH RECOMMENDED BLACK & DECKER 12 & 24 VOLT PRODUCTS.**
4. **FOLLOW ALL SAFETY INSTRUCTIONS.**
5. **DO NOT CHARGE OR DISCHARGE BATTERY IN AN EXPLOSIVE ENVIRONMENT.**
6. **UNPLUG BATTERY PACK FROM CHARGER OR TOOL** when servicing and cleaning.
7. **DO NOT ATTEMPT TO REPAIR THE BATTERY PACK OR CHARGER.** Any repairs must be made by authorized Black & Decker Service Centers.

8. **CAUTION** — Do not insert any metal objects into either receptacle — **THIS ACTION MAY CAUSE A BURN.**
9. **DO NOT INCINERATE OR MUTILATE** — Batteries contain toxic materials.
10. **USE CHARGER NO. 98009 or 98034 ONLY** when charging battery pack.
11. **DO NOT LEAVE CHARGER PLUGGED INTO WALL OUTLET** when not in use.
12. **DO NOT PLUG CHARGER INTO ANY RECEPTACLE OTHER THAN THOSE DESCRIBED IN THIS MANUAL.**
13. **DISCONNECT THE TOOL FROM THE BATTERY PACK** when leaving the tool unattended.

## SAVE THESE INSTRUCTIONS

**NOTE:** Your 98021 Battery Pack was shipped in a partially charged condition. At the time of purchase and before initial use charge the battery pack for 1 hour as described in these instructions.

#### 24 Volt Usage

1. Slide the top door to the side so that the socket pictured in Figure 2 is exposed.

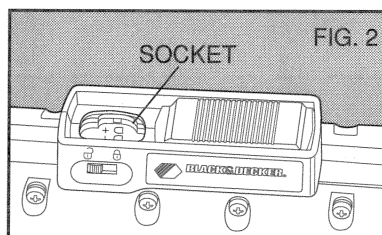

2. Unlock the plug locking ring by rotating the tabs so that they align with the "Unlocked" emblem on the housing, as shown in Figure 3.

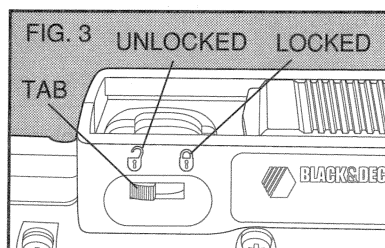

3. Insert the 24 volt tool plug firmly into the socket. **NOTE:** The plug is designed so that it will only fit one way; if it doesn't fit, turn it around.
4. Lock the plug locking ring by rotating the tabs so that they align with the "Locked" emblem on the housing . . . the tool is now ready to operate.
5. Follow all operating instructions in the tool's instruction manual.

#### 12 Volt Usage

Your battery pack has a 12 volt receptacle designed to accept 12 volt automotive type (cigarette lighter) plugs. This may be used for 12 volt lights or other 12 volt products with cigarette lighter plugs. (These other products are not part of the Thundervolt system.)

1. Slide the top door to the side so that the socket pictured in Figure 1 is exposed.

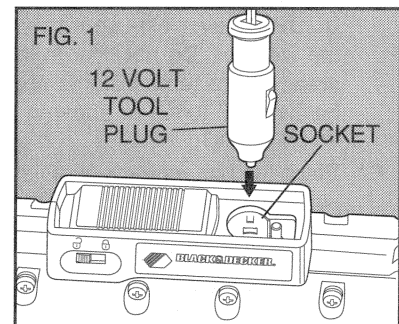

2. Insert the 12 volt tool plug firmly into the socket . . . the tool is now ready to operate.
3. Follow all safety and operating instructions in the tool's instruction manual.

**NOTE:** The 12 volt receptacle described above is also used for charging the battery pack. See charging instructions next page.

#### Circuit Protector

Your power pack is equipped with a circuit protector to prevent damage to the system in the event of an accidental overload of the tool. If the power pack fails to operate or accept a charge, check and reset the circuit protector as required by pushing in the plastic button, shown in Figure 4.

# CHARGING

## 98009 High Performance Lead Acid Battery Charger

### Important Charger Safety Instructions

1. **SAVE THESE INSTRUCTIONS**—This manual contains important safety and operating instructions for battery charger Model 98009.
2. Before using battery charger, read all instructions and cautionary markings on (1) battery charger, (2) battery, and (3) product using battery.
3. **CAUTION** — To reduce risk of injury, charge only 98021 rechargeable battery pack or 12 Volt Lead Acid Rechargeable Automobile Batteries. Other types of batteries may burst causing personal injury and damage.
4. To reduce risk of electric shock, unplug charger from outlet before attempting any maintenance or cleaning.
5. **PLACE THE CHARGER INDOORS**, never expose it to the weather. Do not charge in areas where temperatures are below 32°F (0°C) or above 104°F (72°C).
6. Place the battery pack on a flat surface away from water, a heat source, or flame. Keep the cord away from sharp edges, a heat source, oil and other chemicals.
7. Choose a spot away from chemicals or other corrosive materials.
8. Use the charger only with standard household outlets,
9. **PLUG CHARGER DIRECTLY INTO AN ELECTRICAL OUTLET. DO NOT** use an extension cord unless absolutely necessary. For further details, refer to Table 1. **DO NOT ABUSE THE CORD.** Never carry charger by cord or yank it to disconnect from an outlet.
10. **MAINTAIN WITH CARE. UNPLUG** the charger before attempting any routine cleaning or maintenance.
11. **DO NOT** operate a damaged charger. Have damaged cords or charger replaced immediately by an authorized Black & Decker Service Center.

12. Do not expose charger to rain or snow.
13. Use of an attachment not recommended or sold by the battery charger manufacturer may result in a risk of fire, electric shock, or injury to persons.
14. To reduce risk of damage to electric plug and cord, pull by plug rather than cord when disconnecting charger.
15. Make sure cord is located so that it will not be stepped on, tripped over, or otherwise subjected to damage or stress.
16. Do not operate charger with damaged cord or plug — replace them immediately.
17. Do not operate charger if it has received a sharp blow, been dropped, or otherwise damaged in any way; take it to a qualified serviceman.
18. Do not disassemble charger; take it to a qualified serviceman when service or repair is required. Incorrect reassembly may result in a risk of electric shock or fire.

### Charging the Battery Pack (Using the 98009 Charger)

The 98009 Charger is designed to charge a 98021 Battery Pack in approximately 1 hour.

1. Plug the charger's output plug firmly into the 12 volt receptacle of the battery pack, as shown in Figure 4. Make sure it's plugged in all the way.

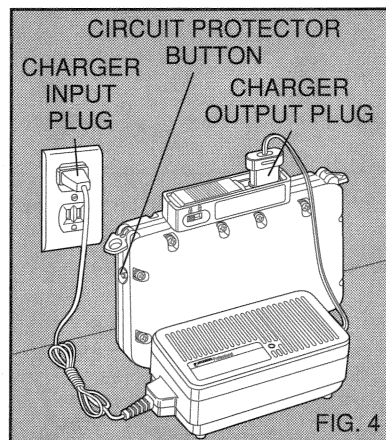

2. Plug the charger's input plug into a standard household electrical outlet.
3. As soon as you plug the charger into the outlet, the light on the top of it will come on.

4. After the battery pack reaches 90% of full charge, the light will begin blinking on and off very slowly (Approximately 1 minute 20 seconds on and 1 minute 40 seconds off).
5. When the battery pack reaches full charge, the light will go out. At this time the charger is still operating, producing a maintenance charge to keep the battery pack fresh.

In some rare cases, a fully depleted battery will not hold a charge but will continue to accept charging from the charger. If you find that the charger light is still glowing after several hours, take or send the battery pack to your closest Black & Decker Service Center for a thorough inspection.

Do not store battery pack for long periods without a full charge.

Battery packs must be recharged periodically (every 4 months) if they are to be stored for long periods of time. The battery used in the 98021 Battery Pack will self discharge over a period of time depending on storage conditions. The battery pack should be fully charged after every usage.

## Extension Cords

An extension cord should not be used with the 98009 charger unless absolutely necessary. Use of improper extension cord could result in a risk of fire and electric shock. If extension cord must be used, make sure:

- a. That pins on plug of extension cord are the same number, size, and shape as those of plug on charger;
- b. That extension cord is properly wired and in good electrical condition; and
- c. That wire size is large enough for AC ampere rating of charger as specified in Table 1.

**TABLE 1**  
RECOMMENDED MINIMUM AWG SIZE FOR EXTENSION CORDS FOR BATTERY CHARGERS

Ampere rating of charger Equal to or greater than	but less than	Length of Cord, Feet / Meters			
		25 (7.6M)	50 (15.2M)	100 (30.4M)	150 (45.6M)
0	2	18 (7.5mm <sup>2</sup> )	18 (7.5mm <sup>2</sup> )	18 (7.5mm <sup>2</sup> )	16 (7.5mm <sup>2</sup> )
SIZE OF CORD					

# CHARGER FROM VEHICLE AND AUTOMOTIVE CHARGING ADAPTOR



**ThunderVolt™**  
24 Volt Cordless System

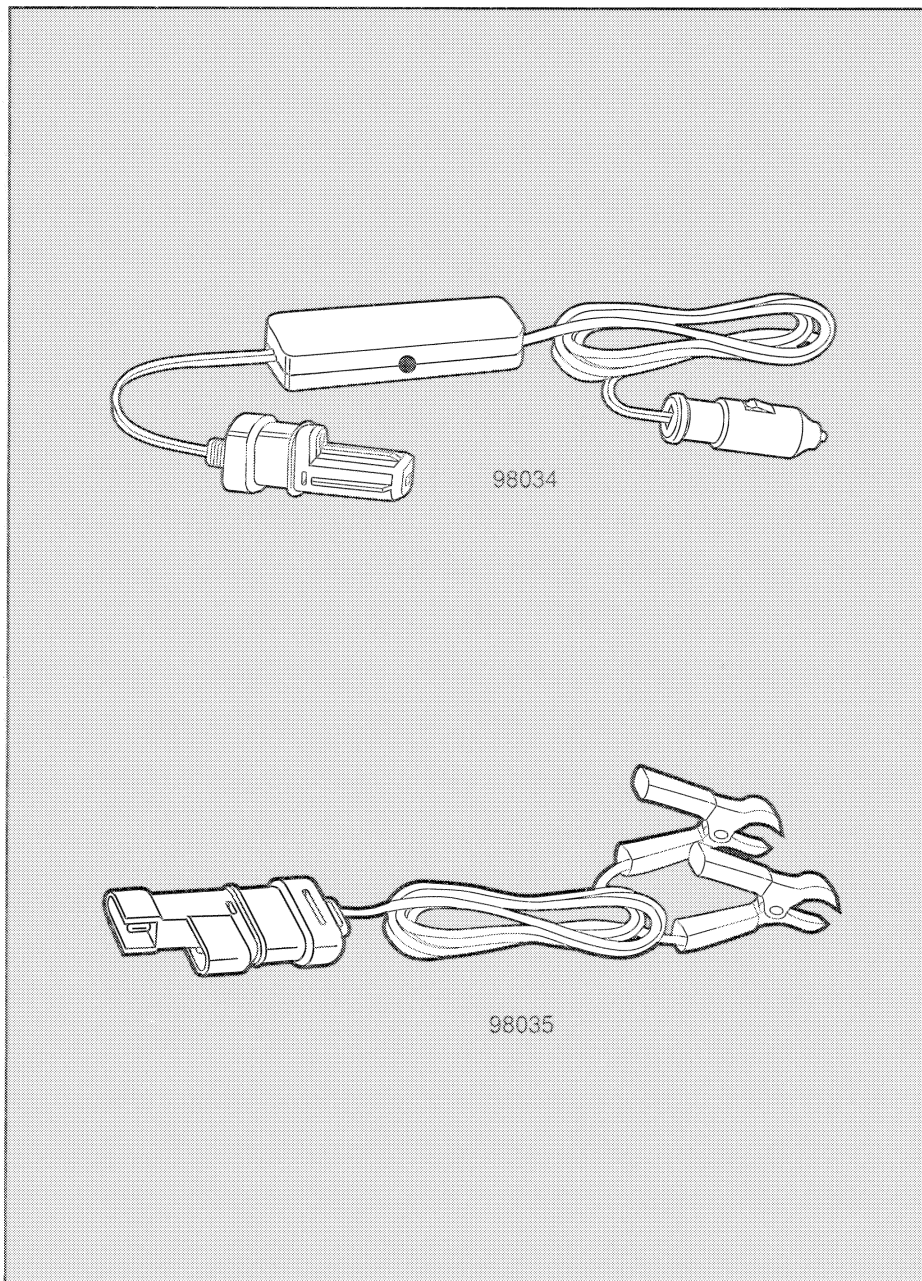

**98034 Charger from Vehicle &  
98035 Automotive Charging Adaptor**

# CHARGING THE CAR BATTERY

## 98034 Charger From Vehicle

(Charging the 98021 battery pack using a vehicle with a 12 volt cigarette lighter socket and the 98034 Charger From Vehicle)

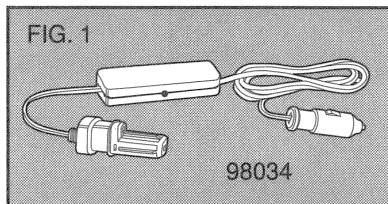

**NOTE:** The 98009 charger is not used at the same time as the 98034 Charger From Vehicle. The Charger From Vehicle is used to supplement your battery pack charging. For best results, you should charge your battery pack with your 98009 charger after every day's use.

1. Start your car's engine and set the parking brake. Allow the engine to idle with the transmission in park (if automatic) or neutral (if manual).
2. Plug the output plug of the 98034 Charger From Vehicle into the 12 volt receptacle of the power pack, as shown in Figure 2.

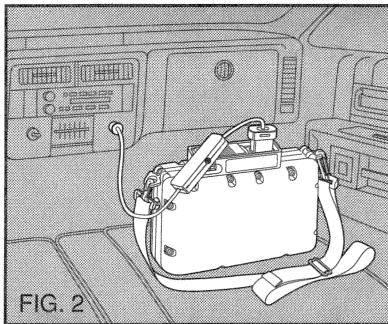

3. Plug the input plug of the Charger From Vehicle into the cigarette lighter receptacle of your automobile.

Your charger is equipped with a small red light that will begin to glow when the car reaches about 35 mph (55Kph). At speeds slower than 35 mph (55Kph), the charging level will be insufficient to charge the battery pack and the light will go out.

When the battery pack is fully charged, the light will go

out and remain out, even when driving at 35 mph (55Kph) or faster.

4. Drive your car normally. After about one hour, your battery will be charged. **NOTE:** The Charger From Vehicle will NOT fully charge the power pack under engine idling conditions. The engine must be operated at considerably higher than idle RPM to fully charge the power pack. This RPM is best achieved by driving the car at normal speeds (above 35 mph (55Kph)).

**NOTE: DO NOT CHARGE THE BATTERY PACK IN THE ABOVE MANNER BY LETTING THE CAR IDLE UNATTENDED OR IN A CLOSED GARAGE.**

## Charging the Car Battery using the 98035 Automotive Charging Adaptor

A special accessory that enables you to charge your car battery when used in conjunction with the 98009 charger.

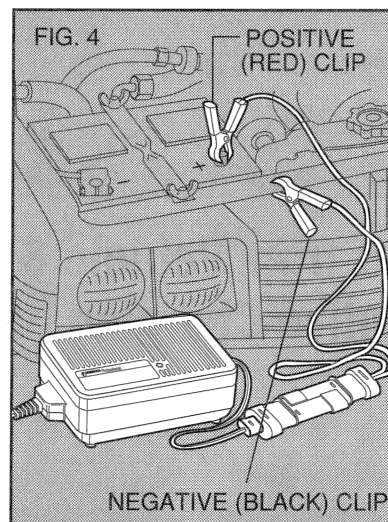
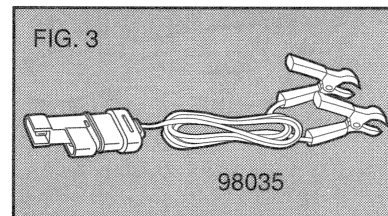

## Important Safety Instructions

1. **WARNING — RISK OF EXPLOSIVE GASES.**
  - a. **WORKING IN VICINITY OF A LEAD-ACID BATTERY IS DANGEROUS. BATTERIES GENERATE EXPLOSIVE GASES DURING NORMAL BATTERY OPERATION. FOR THIS REASON, IT IS OF UTMOST IMPORTANCE THAT EACH TIME BEFORE USING YOUR CHARGER, YOU READ THIS MANUAL AND FOLLOW THE INSTRUCTIONS EXACTLY.**
  - b. To reduce risk of battery explosion, follow these instructions and those published by battery manufacturer and manufacturer of any equipment you intend to use in vicinity of battery. Review cautionary marking on these products and on engine.
2. **PERSONAL PRECAUTIONS**
  - a. Someone should be within range of your voice or close enough to come to your aid when you work near a lead-acid battery.
  - b. Have plenty of fresh water and soap nearby in case battery acid contacts skin, clothing, or eyes.
  - c. Wear complete eye protection and clothing protection. Avoid touching eyes while working near battery.
  - d. If battery acid contacts skin or clothing, wash immediately with soap and water. If acid enters eye, immediately flood eye with running cold water for at least 10 minutes and get medical attention immediately.
  - e. **NEVER** smoke or allow a spark or flame in vicinity of battery or engine.
  - f. Be extra cautious to reduce risk of dropping a metal tool onto battery. It might spark or short-circuit battery or other electrical part that may cause explosion.

# CHARGING THE CAR BATTERY

- g. Remove personal metal items such as rings, bracelets, necklaces, and watches when working with a lead-acid battery. A lead-acid battery can produce a short-circuit current high enough to weld a ring or the like to metal, causing a severe burn.
  - h. Use charger for charging a **LEAD-ACID** automobile battery only. It is not intended to supply power to a low-voltage electrical system. Do not use battery charger for charging dry-cell batteries that are commonly used with home appliances. These batteries may burst and cause injury to persons and damage to property.
  - i. **NEVER** charge a frozen battery.
  - j. Never attempt to charge any battery except 12 volt lead acid rechargeable automobile batteries. Never attempt to charge motorcycle, snowmobile, garden tractor, lawnmower, wheelchair, golf cart or similar batteries. To do so will severely damage the batteries and may cause personal injury.
  - k. This product is not intended for marine use.
3. **PREPARING TO CHARGE**
- a. If necessary to remove battery from vehicle to charge, always remove grounded terminal from battery first. Make sure all accessories in the vehicle are off, so as not to cause an arc.
  - b. Be sure area around battery is well ventilated while battery is being charged. Gas can be forcefully blown away by using a piece of cardboard or other nonmetallic material as a fan.
  - c. Clean battery terminals. Be careful to keep corrosion from coming in contact with eyes.

- d. Add distilled water in each cell until battery acid reaches level specified by battery manufacturer. This helps purge excessive gas from cells. Do not overfill. For a battery without cell caps, carefully follow manufacturer's recharging instructions.
  - e. Study all battery manufacturer's specific precautions such as removing or not removing cell caps while charging and recommended rates of charge.
  - f. Determine voltage of car battery by referring to the car's owner's manual and make sure that the battery is rated at 12 volts. If it is not so rated, **IT CAN NOT BE CHARGED WITH THIS CHARGER.**
4. **CHARGER LOCATION**
- a. Never place charger directly above battery being charged; gases from battery will corrode and damage charger.
  - b. Never allow battery acid to drip on charger when reading gravity or filling battery.
  - c. Do not operate charger in a closed-in area or restrict ventilation in any way.
  - d. Do not set a battery on top of charger.
  - e. Locate charger as far away from battery as the charging cables permit.
5. **DC CONNECTION PRECAUTIONS**
- a. **CONNECT AND DISCONNECT DC OUTPUT CLIPS ONLY AFTER REMOVING AC CORD FROM ELECTRIC OUTLET. NEVER ALLOW CLIPS TO TOUCH EACH OTHER.**
  - b. Attach clips to battery posts and/or frame positions and twist or rock back and forth several times to make a good connection. This tends to keep clips from slipping and helps to reduce risk of sparking.

6. **FOLLOW THESE STEPS WHEN BATTERY IS INSTALLED IN VEHICLE. A SPARK NEAR BATTERY MAY CAUSE BATTERY EXPLOSION. TO REDUCE RISK OF A SPARK NEAR BATTERY:**
- a. Position all cords to reduce risk of damage by hood, door, or moving engine part.
  - b. Stay clear of fan blades, belts, pulleys, and other parts that can cause injury to persons.
  - c. Check polarity of battery posts. POSITIVE (POS, P, +) battery post usually has larger diameter than NEGATIVE (NEG, N, -) post.
  - d. Determine which post of battery is grounded (connected) to the chassis. If negative post is grounded to chassis (as in most vehicles), see item e. If positive post is grounded to the chassis, see item f.
  - e. For negative-grounded vehicle, connect POSITIVE (RED) clip from battery charger to POSITIVE (POS, P, +) ungrounded post of battery. Connect NEGATIVE (BLACK) clip to vehicle chassis or engine block away from battery. **NOTE: DO NOT FACE BATTERY WHEN MAKING FINAL CONNECTION.** Do not connect clip to carburetor, fuel lines, or sheetmetal body parts. Connect to a heavy gauge metal part of the frame or engine block.
  - f. For positive-grounded vehicle, connect NEGATIVE (BLACK) clip from battery charger to NEGATIVE (NEG, N, -) ungrounded post of battery. Connect POSITIVE (RED) clip to vehicle chassis or engine block away from battery. Do not connect clip to carburetor, fuel lines, or sheetmetal body parts. Connect to a heavy gauge metal part of the frame or engine block.

# CHARGING THE CAR BATTERY

- g. When disconnecting charger, disconnect AC cord, remove clip from vehicle chassis, and then remove clip from battery terminal.
- h. See operating instructions below for length of charge information.

**7. FOLLOW THESE STEPS WHEN BATTERY IS OUTSIDE VEHICLE. A SPARK NEAR THE BATTERY MAY CAUSE BATTERY EXPLOSION. TO REDUCE RISK OF A SPARK NEAR BATTERY:**

- a. Check polarity of battery posts. POSITIVE (POS, P, +) battery post usually has a larger diameter than NEGATIVE (NEG, N, -) post.
- b. Attach at least a 24-inch- (61cm) long 6-gauge (AWG) insulated battery cable (not supplied with system) to NEGATIVE (NEG, N, -) battery post.
- c. Connect POSITIVE (RED) charger clip to POSITIVE (POS, P, +) post of battery.
- d. Position yourself and free end of cable as far away from battery as possible — then connect NEGATIVE (BLACK) charger clip to free end of cable.
- e. Do not face battery when making final connection.
- f. When disconnecting charger, always do so in reverse sequence of connecting procedure and break first connection while as far away from battery as practical.

**Charging the Car Battery  
(Using the 98009 Charger and the 98035 Automotive Charging Adaptor)**

- 1. Always plug the output cord from the 98009 charger all the way into the matching end of the Automotive Charging Adaptor first.
- 2. With the charger unplugged from the wall, attach the positive (RED) clip from the Automotive Charging Adaptor to the positive (+) post of the car's battery, as shown in Figure 5.
- 3. Attach the negative (BLACK) clip to any solid metal part of the car's frame in accordance with safety instruction number 6e.

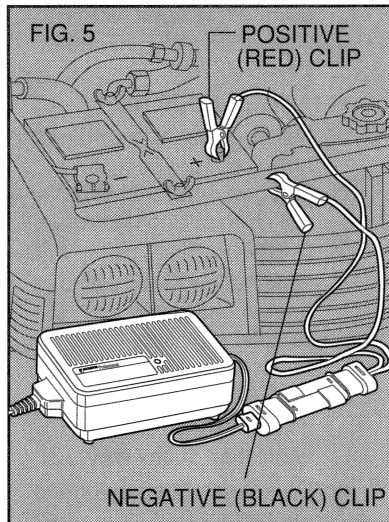

- 4. Plug the input cord to the charger into any conventional household electrical outlet.
  - a. If the red charging light on the charger does not come on, unplug the charger from the wall and check to make sure that you have connected the battery charging cables correctly as described above.

Your charger has a built-in polarity protection device which prevents the charger from operating if the battery cables are attached backwards.

- b. If the red charging light blinks off and on for more than 5 hours, check to make sure that none of the car's accessories (including interior lights) are operating.

**CAUTION:** Check frequently to see that red charging light on charger is glowing. As soon as the red light goes out, signifying that the battery has reached full charge, unplug the charger from the wall and disconnect the cables from the battery. To leave the charger connected after the light goes out may damage the battery.

Automobile batteries may require over 12 hours to reach full charge. Small automobile batteries with a partial charge may require only 2 - 3 hours to reach full charge. If your automobile battery is not charged after 16 hours, disconnect it from your car and try charging it again. If it still won't charge, it is probably defective and should be checked by a qualified mechanic.

## Accessories

The accessories listed in this manual are available at extra cost from your local dealer or Black & Decker Service Center.

**CAUTION:** The use of any other accessories or attachments may be hazardous.

### 98034 Charger From Vehicle

The Charger From Vehicle is used for charging the 98021 Battery Pack from your car battery. See page 28 and Figures 1 & 2 for operating instructions.

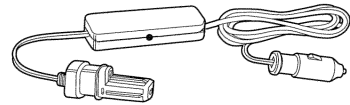

### 98035 Automotive Charging Adaptor

The Automotive Charging Adaptor is used to charge your car battery with the 98009 charger. See pages 28, 29 & 30 and Figure 5 for operating instructions.

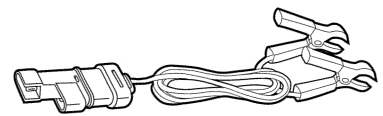

### 98024 Battery Pack Belt and Pouch

The belt and pouch are designed to carry the battery pack comfortably and conveniently. The pouch is worn against the small of the back, as shown in Figure 6 and is held in place with the attached belt.

Cinch the belt snugly to hold the pack firmly and tuck any extra material into the loops provided. Belt adjustments are provided on both the left and right side of the buckle. The belt will adjust from 24" (61cm) to 44" (110cm) waist size.

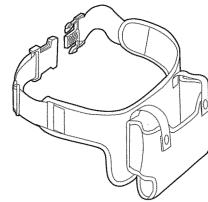

### 98027 Battery Pack Shoulder Strap

The Shoulder Strap can be used instead of the Battery Pack Belt and Pouch if you prefer. The Battery Pack shown on page 24 of this manual shows the Shoulder Strap.

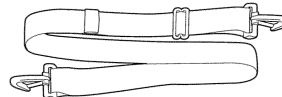

### 98028 Holster

The Holster is provided for convenience and will fit most of the tools in the Thundervolt System. It is designed for right or left handed use.

Holster fits 1811, 1815, 1824, 1827, 1829.

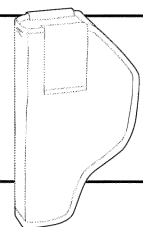

### 98031 Coiled 6 ft. (1.8 Meter) Power Cord

The Coiled Power Cord is used to connect the 24 volt tools to the battery pack. See page 25 and Figures 2 & 3 for operating instructions.

**CAUTION:** Do not attempt to use 98031 Power Cord in conjunction with 98032 Power Cord. Do not use more than one 98031 Power Cord in any single application. Do not use 98031 power cord unless it is in good physical condition.

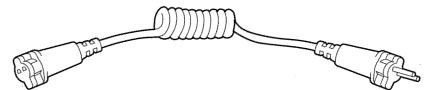

### 98032 13 ft. (4 Meter) Power Cord

The 98032 13 ft. (4M) Power Cord is used to connect the 24 volt tools to the battery pack. See page 25 and Figures 2 & 3 for operating instructions. **CAUTION:** Do not attempt to use 98032 Power Cord in conjunction with 98031 Power Cord. Do not use more than one 98032 Power Cord in any single application. Do not use 98032 Power Cord unless it is in good physical condition.

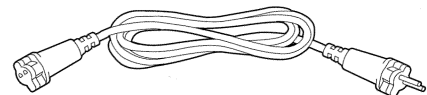

# WARRANTY

## Important

To assure product SAFETY and RELIABILITY, repairs, maintenance and adjustment should be performed by BLACK & DECKER Service Centers or other qualified service organizations, always using BLACK & DECKER replacement parts.

## Commercial/Industrial Use Warranty

Black & Decker (U.S.) Inc. warrants any Thundervolt product for one year from date of purchase. We will repair without charge, any defects due to faulty material or workmanship. Please return the complete unit, transportation prepaid, to any Black & Decker Service Center or Authorized Service Station listed under "Tools Electric" in the yellow pages. This warranty does not apply to accessories or damage caused where repairs have been made or attempted by others. Different warranties may apply outside the United States.

Every Black & Decker tool is of the highest quality. If you wish to contact us in the United States regarding this product, please call toll free between 8:00 a.m. and 5:00 p.m. EST, Monday through Friday.

1-800-762-6672

Like most Black & Decker tools, your tool is listed by Underwriter's Laboratories to ensure that it meets stringent safety requirements.

This symbol on the nameplate means the product is listed by Underwriter's Laboratories, Inc.



See 'Tools-Electric'  
—Yellow Pages—  
for Service & Sales



**BLACK & DECKER®**

BLACK & DECKER (U.S.) INC., U.S. Power Tools Group, 10 North Park Drive, Hunt Valley, MD 21030 U.S.A.

1808/1811/1813/1815/1817/1819/1820/1824/1827/1829/1832/98009/98021

Form No. 741923-01

Copyright ©1990 Black & Decker Printed in U.S.A.